

WARMTH OF HEARTH & HOME

DEFRO
home

operating manual

fireplace with water system

DEFRO HOME NAVI series

model

SM □

ME □

version

G □

**DEKLARACJA ZGODNOŚCI WE
DECLARATION OF CONFORMITY EC**

nr DH 5/P1/01/2022

DEFRO R. Dziubeta spółka komandytowa

26-067 Strawczyn, Ruda Strawczyńska 103A

DEKLARUJE / DECLARES

z pełną odpowiedzialnością, że produkt / *with all responsibility, that the product*

**Wkład kominkowy / Fireplace insert
DEFRO HOME NAVI
(typ/type DEFRO HOME NAVI)**

został zaprojektowany, wyprodukowany i wprowadzony na rynek zgodnie z następującymi dyrektywami:
has been designed, manufactured and placed on the market in conformity with directives:

**Rozporządzenie Parlamentu Europejskiego 305/2011 / Regulation of the European Parliament 305/2011
Dyrektywa ErP 2009/125/WE / Directive ErP 2009/125/WE
Rozporządzenie Delegowane Komisji (UE) 2015/1186 / Commission Delegated Regulations (EU) 2015/1186
Rozporządzenie Komisji (UE) 2015/1185 / Commission Regulation (EU) 2015/1185**

i niżej wymienionymi normami zharmonizowanymi:
and that the following relevant Standards:

PN-EN 13229:2002

dokumentacja techniczna / technical documentation

Wyrób oznaczono znakiem:
Product has been marked:



Ta deklaracja zgodności traci swą ważność, jeżeli we wkładzie kominkowym DEFRO HOME NAVI wprowadzono zmiany, została przebudowana bez naszej zgody lub jest użytkowana niezgodnie z instrukcją obsługi. Niniejsza deklaracja musi być przekazana wraz z nagrzewnicą w przypadku odstąpienia własności innej osobie.

This Declaration of Conformity becomes invalid if any changes have been made to the DEFRO HOME NAVI Fireplace, if its construction has been changed without our permission or if the air heater is used not in accordance with the operating manual. This Declaration shall be handed over to a new owner along with the title of ownership of the air heater.

**Wkład kominkowy DEFRO HOME NAVI jest wykonywany zgodnie z dokumentacją techniczną przechowywaną przez:
DEFRO HOME NAVI Fireplace insert has been manufactured according to technical documentation kept by:
DEFRO R. Dziubeta spółka komandytowa, 26-067 Strawczyn, Ruda Strawczyńska 103a.**

*Imię i nazwisko osoby upoważnionej do przygotowania dokumentacji technicznej: Mariusz Dziubeta
Name of the person authorized to compile the technical documentation: Mariusz Dziubeta*

Imię i nazwisko oraz podpis osoby upoważnionej do sporządzenia deklaracji zgodności w imieniu producenta: Robert Dziubeta
Name and signature of the person authorized to compile a declaration of conformity on behalf of the manufacturer: Robert Dziubeta

Dwie ostatnie cyfry roku, w którym oznakowanie zostało naniesione: 18
Two last digits of the year of marking: 18

Ruda Strawczyńska, dn. 03.01.2022 r.
miejsce i data wystawienia
place and date of issue.

Robert Dziubeta
prezes zarządu / CEO

Dear Customer,

We would like to inform you that we make every effort to offer the products of quality fulfilling the most restrictive standards and warranting operational safety. All the devices are produced in accordance with the requirements of relevant EU directives and have CE safety mark confirmed by the Declaration of Conformity EC.



We appreciate all your comments and proposals regarding our level of service. We appreciate your comments and proposals regarding our devices and the level of service provided by our Partners and Technical Support/Service.

DEFRO R. Dziubela sp.k.

The content of this Operating Manual is a property of DEFRO R. Dziubela sp.k.
Any copying, duplicating, publishing of the content of this Manual without the prior written consent of DEFRO R. Dziubela sp.k. is forbidden.

Dear Customer,

We would like to thank you for choosing the high-quality DEFRO product which will ensure your safety and operational reliability.

As our customers, you can always count on the help of the DEFRO Service Centre, which is ready to ensure the continuous efficiency of your equipment.

Please note that in order to use the equipment safely and efficiently, it is crucial to get familiar with the following directions.

- Read and follow this Operating Manual - useful remarks concerning the proper operation of the equipment can be found there.
- Determine if all parts have been delivered or if the fireplace was not damaged during transport.
- Check the data on the rating plate against the warranty card.
- Prior to starting the device, check the flue connection against connection recommendations included in this manual and appropriate national regulations.

Basic usage rules are to be obeyed while using the equipment. Do not open the doors during the operation of the device.

DEFRO Service Centre or Authorized DEFRO Service should be always contacted when any intervention is necessary because only these parties have original spare parts and are properly trained within the scope of installation and operation of DEFRO equipment.

For your safety and equipment use convenience please get acquainted with this operating manual and send back a correctly filled copy of the Warranty Card to the following address:



DEFRO R. Dziubela sp.k.. - Centrum Serwisowe
Ruda Strawczyńska 103a
26-067 Strawczyn



serwis@defro.pl

By sending back your Warranty Card, you will be registered in our DEFRO products users' database and we will be able to provide you with quick and professional technical support.

If you do not send back a correctly filled in Warranty Card and the equipment quality and completeness receipt within the period of up to two weeks after the date of installation but no longer than within six months, after purchasing, the warranty will become invalid. This results in delays with repairs and the necessity of **covering costs** of service and traveling expenses.

Thank you for understanding.
Yours sincerely,

DEFRO R. Dziubela sp.k.

Table of contents

1.	INFORMATION	5
2.	BASIC SAFETY RULES	5
2.1.	Safety warnings	5
2.2.	Warnings related to operation	6
3.	INTENDED USE	6
4.	TECHNICAL SPECIFICATION	6
4.1.	Design	6
4.2.	TECHNICAL DATA	7
4.3.	Equipment	9
4.4.	Fuel parameters	9
4.5.	Spare parts	9
5.	TRANSPORT AND INSTALLATION	9
5.1.	Transport and storage	9
5.2.	Working environment	10
5.3.	Hot air distribution system	11
5.3.1.	Gravity system for hot air distribution	11
5.3.2.	Forced system for hot air distribution	11
5.4.	Connection to external air intake	11
5.5.	Installation to the flue	12
5.6.	Installation in central heating system	12
6.	USAGE AND OPERATION	13
6.1.	Filling water system with water	13
6.2.	Introductory remarks	14
6.3.	First start-up and operation	14
6.4.	Damping	14
6.5.	Low temperature corrosion	15
7.	CLEANING AND MAINTENANCE	15
7.1.	Basic operations and cleaning by the user	15
7.2.	Cleaning before each starting	15
7.3.	Window panel cleaning	15
7.3.1.	Doors/gaskets	16
7.3.2.	Furnace chamber	16
7.3.3.	Flue	16
7.3.4.	Water system	16
7.4.	Periodic inspection by authorized service	16
7.5.	Disassembly of doors for basic version	16
7.6.	Disassembly of window panel for basic version	17
7.7.	Disassembly of deflector	17
7.8.	Disassembly of ceramic tiles	17
7.9.	Shutting the stove down	18
8.	TROUBLESHOOTING	18
9.	MEASURES IN CASE OF FIRE IN THE FLUE /SOOT IGNITION/	18
10.	REMOVAL DUE TO WEAR-OUT	19
11.	REMARKS ON FIREPLACE INSERT USAGE	19
12.	PRODUCT WARRANTY TERMS AND CONDITIONS	19
12.1.	Warranty conditions "48h Service"	21
13.	WARRANTY CARD	23
14.	CARRIED OUT WARRANTY REPAIRS AND MAINTENANCE	24
15.	WARRANTY CARD (copy to send back)	25
16.	COMPLAINT FORM	27
17.	COMPLAINT FORM	29
18.	COMPLAINT FORM	31
19.	REGISTER OF INSPECTIONS OF SMOKE DUCT	32

1. INFORMATION

The operating manual is an integral and essential part of the product and must be forwarded to the user also in the case when the property is transmitted. Users should carefully read the manual and save it for the future because all remarks included there are important guidelines concerning safety during installation, usage and maintenance.

Installation of the fireplace must be carried out in accordance with the mandatory standards in the country of destination, according to guidelines of the manufacturer and by qualified personnel. Improper installation of the device can be a reason for personal injuries and damage to property for which the manufacturer is not liable.

The fireplace can be used only for the purpose it was explicitly intended. Any other use should be treated as inappropriate and in consequence as dangerous.

In the case of error during installation, usage or maintenance works caused by non-observance of the legislation, applicable regulations or instructions contained in this manual (or others, delivered by the manufacturer) the manufacturer rejects any contractual or non-contractual liability for resulting damages and the warranty for the device becomes void.

All illustrations, pictures and photos are only indicative.

Versions of the publication

Due to continuous improvement of the product, DEFRO reserves the right to update this publication without prior notice.

The content of this Operating Manual is a property of DEFRO. Any copying, duplicating, or publishing of content of this User's Manual without the prior written consent of DEFRO is forbidden.

Manual storage and browsing of its contents

We recommend taking care of this manual and storing it in an easily and quickly available location. If this manual has been lost, damaged or destroyed you should request a copy in the sales outlet or directly from the Manufacturer providing identification data of the product. All the most important information included in the operating manual is marked with "bold" and has symbols pointing out the user's attention to hazards that can be present during the operation of the dry stove with a water jacket. The symbols used in the text are explained below:



Danger!

Direct threat to life and health! Non-compliance with the recommendations marked in this way and misuse may result in death or major injuries.



Danger!

Danger from electrical voltage! Incorrect installation and incorrect electrical connections may cause danger to life by electric shock.



Note!

Warning symbol indicates that you should read carefully and understand the given information, to which it relates. Non-compliance with those recommendations may result in major damage to the equipment and create a hazard to the user or the environment.



Danger!

Direct threat to health! Non-compliance with the recommendations distinguished in this way may cause a fire or burns.



Hint!

Informative symbol. Useful information and hints are marked in this way.

2. BASIC SAFETY RULES

2.1. SAFETY WARNINGS



- The national and local provisions should be met.
 - The equipment should be installed in compliance with the legal standards applicable in the given location, region or country.
 - The equipment should be used by persons (including children) with impaired physical, sensory, and mental capabilities and by persons without experience and required knowledge provided that such operation is not carried out under their supervision or after proper instruction by a person responsible for their safety.
 - You should always observe the guidelines given in the operating manual to ensure the correct use of the equipment and to prevent accidents.
 - Operation and adjustment should be carried out by adults. Errors and incorrect settings can cause hazardous situations and/or incorrect operations.
 - Prior to any operations the user (or any person operating the equipment) should read and understand the whole contents of this manual.
 - Equipment should be used only as intended. Each other use is considered as misuse and hazardous as a consequence.
 - The equipment should not be used as a ladder or object to lean against.
 - Prior to installation, you should make sure that the substrate will resist the force of the fireplace insert considering its weight.
 - In the case of disturbances in operation, the equipment can be restarted only when the occurred problem has been removed and the equipment is brought back to its original condition.
 - The user is fully responsible for misuse of the product and relieves DEFRO from any civil and criminal liability.
 - All types of modifications or replacement of equipment parts with non-original components or without authorization may present a risk for the operator and relieves DEFRO from any civil and criminal liability.
 - Incorrect installation or maintenance (incompatible with the contents of this manual), can cause injuries to people, animals or property damage. Then DEFRO shall be relieved of any civil or criminal liability.
-
- 
- Part of the fireplace insert surface is very hot (doors, handle, window panel, flue gas discharge pipe, etc.). You should avoid direct contact with such components without suitable protective clothing or protective equipment such as e.g. heat-resistant gloves.
 - Do not touch the window panel after heating up the fireplace insert.
 - Keep children away from the equipment when it is operating because each hot surface can cause burns.
 - It is forbidden to use a fireplace insert when glass is cracked.
 - Do not place and dry the underwear on the equipment. Possible dryers for hanging underwear or similar should be located at an adequate distance from the equipment - fire hazard.
 - It is absolutely forbidden to open the doors if the flue is on fire. Then call the appropriate services.
 - It is recommended to keep a distance 400 mm between hot parts of the fireplace insert and medium inflammable materials; otherwise use commercially available insulation materials. Apply this hint also for

furniture, curtains etc. The minimum distances are given in point 5.2 of the operating manual.

- It is absolutely forbidden to use flammable liquid for equipment firing up.
- If the substrate, on which the equipment is located, is made of inflammable materials, such as parquet or floor lining then you should place a protective plate under it (the plate should protrude 250-300 mm from the front of the equipment).

2.2. WARNINGS RELATED TO OPERATION



- Equipment should be shutdown in the case of failure or incorrect operation.
- Fuel used in the fireplace insert should meet the conditions described in this manual.
- Internal parts of the fireplace insert should not be washed with water.
- Avoid contact with water; above all do not wash any painted surfaces until they are fully cured. The coating on new devices is not an anti-corrosion coating; heat-resistant paint achieves its protective properties only after curing under the influence of heat (after several ignitions).
- Do not expose the body to the action of hot air for a long period of time. Do not heat excessively the room where you are staying and where the equipment is installed. It may have an adverse impact on physical condition and be a reason of health problems.
- Equipment should be installed in rooms with fire protection and equipped with all required components such as supply (with air) and flue gas discharge.
- Fireplace insert and cladding made of ceramics should be stored in rooms free from moisture and they cannot be exposed to adverse effects of the weather.
- It is not recommended to place the body of the fireplace insert directly on the floor and if such floor is made of inflammable materials it should be properly insulated.
- To facilitate possible interventions by the technical personnel you should not place the fireplace insert inside the closed rooms and just by the walls which can also disturb air intake.
- Always make sure and check whether the doors of the combustion chamber are tightly closed when the equipment is operating.
- Equipment consumes the exact amount of air that is required for the combustion process; it is recommended to connect the iron stove to air intake from outside using a suitable pipe and through a special outlet located at the back of the equipment.

ADDITIONAL INFORMATION



- You should contact the sales outlet or qualified personnel authorized by DEFRO in the case of any problems. Request original spare parts if the repair is necessary.
- Use only fuel with properties compatible with the recommendations of this operating manual.
- Check and clean flue gas discharge ducts (connecting piece to flue) periodically.
- Store this manual carefully because it should be available for a whole period of equipment operation. In the case of sale or giving the equipment to the other user you should always make sure whether the product has the manual enclosed.
- Request a new copy from an authorized sales outlet in DEFRO company if it has been lost.

3. INTENDED USE

The DEFRO HOME NAVI fireplace insert as a furnace with manual fuel charge is intended for enclosing or installation into a recess. Housing should not be permanently bonded with the insert, you should have an option to disassemble it.

The DEFRO HOME NAVI fireplace insert is intended for the combustion of hardwood e.g. beech, hornbeam, oak, acacia, maple, birch etc. with moisture content below 20%. It is intended for heating of houses and spaces where it is installed. It can be also used as an additional source of thermal power.

The DEFRO HOME NAVI fireplace insert is equipped with a water system intended for supplying of central heating system. It can operate as only or additional source of supply for the CO system.



The DEFRO HOME NAVI fireplace insert with a water system can be operated only after connection to the central heating system and filling it with water. Only then proper heat discharge is ensured. Operation of the equipment without water and outside the CO system results in loss of warranty.

4. TECHNICAL SPECIFICATION

4.1. DESIGN

Body (1, picture 1) of the DEFRO HOME NAVI fireplace insert is a steel jacket, with a combustion chamber located inside (2). Floor creating chamber for air intake is a basis for the insert. The rear wall and side walls of the combustion chamber are lined with claddings made of concrete insulating refractory. The front wall of the combustion chamber is restricted by a steel door (3) with a heat-resistant window panel (4) and lock (5).

Fuel is combusted on cast-iron grate (8) installed on the base. Ashpan container (9) is located under the grate. Deflector (15) is located over the combustion chamber. It directs flue gas flow and improves the degree of heat exchange.

Air necessary for the combustion process is supplied through an air intake socket (10) equipped with an adjustment mechanism (11). Air intake is located on the floor of the fireplace insert. Openings for the flue gas afterburning system (14) are additionally located in the rear wall of the furnace chamber.

A fireplace insert is equipped with a water system made of steel, consisting of two parts: upper, located over the furnace chamber and side, surrounding three walls of the furnace chamber from half of its height.

Side walls of the fireplace insert are equipped with connecting sockets for the central heating system: two supplying the central heating system (19) and two for return from the central heating system (20). The right side is equipped with a socket of the thermal sensor of the heat exchanger (21) and protective sockets for the heat exchanger (18), while the left wall is equipped with an installation socket for the temperature sensor (23). Installation socket for the vent of the fireplace insert (22) is located on protrusion below the front cleaning hatch (16).

Flue gases are removed to the chimney through a flue (17) located in the upper wall of the water system.

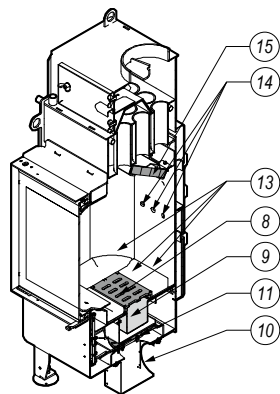
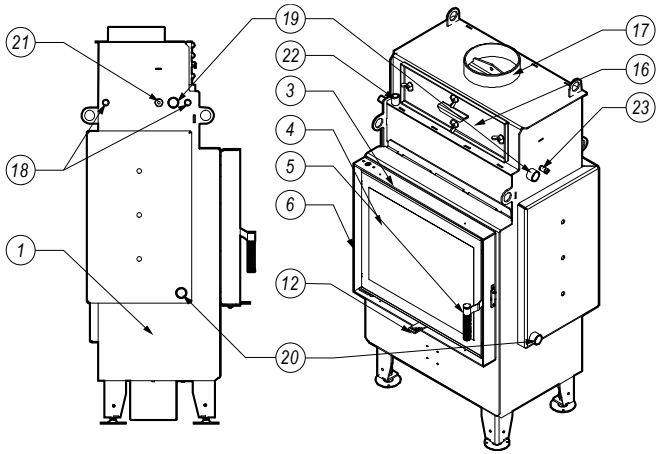

Picture 1. Design of the DEFRO HOME NAVI fireplace insert.

1 – body, 2 – combustion chamber, 3 – doors, 4 – heat-resistant glass pane, 5 – handle with a lock, 6 – frame, 7 – floor, 8 – grate, 9 – ash-pan container, 10 – air intake socket, 11 – adjustment of air inflow, 12 – air inflow adjustment slider, 13 – claddings made of fire-proof concrete, 14 – openings from flue gas afterburning system, 15 – deflector, 16 – front cleanout opening, 17 – flue, 18 – heat exchanger (coil pipe) sockets - $\Phi 1/2"$, 19 – sockets supplying central heating system - $\Phi 1"$, 20 – return sockets of the central heating system - $\Phi 1"$, 21 – assembly connection of thermal sensor of heat exchanger - $\Phi 1/2"$, 22 – vent socket - $\Phi 1/2"$, 23 – assembly connection of temperature sensor - $\Phi 1/2"$.

4.2. TECHNICAL DATA

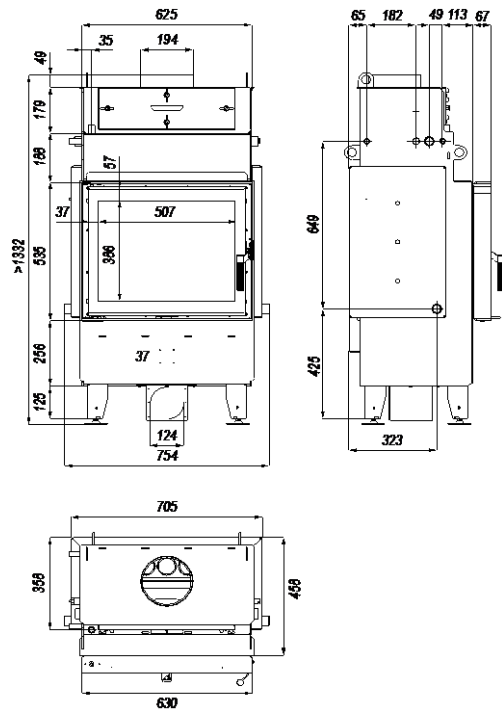

Picture 2. Projections with dimensions of DEFRO HOME NAVI SM fireplace insert.

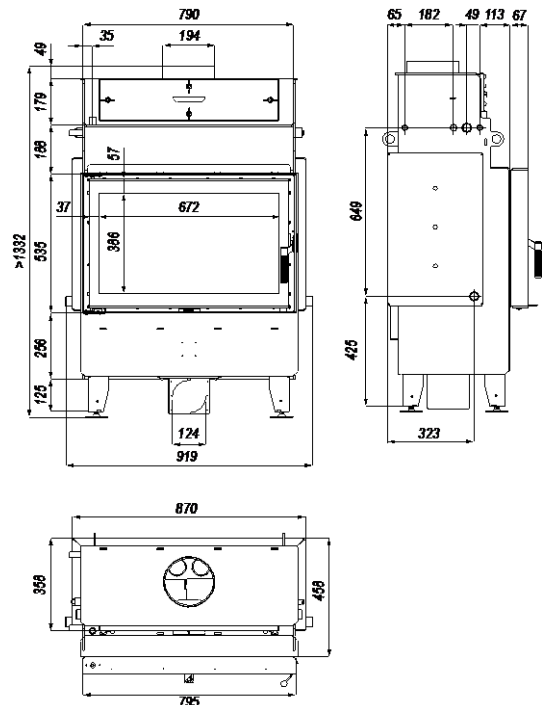

Picture 3. Projections with dimensions of DEFRO HOME NAVI ME fireplace insert.

Table 1. Dimensions of all models of the DEFRO HOME NAVI fire-place insert with covers.

type	dimensions [mm]					
	OA	OB	OC	OD	OE	OF
DH NAVI SM	793.0	74.0	1310.0	398.0	109.0	484.0
DH NAVI ME	958.0	74.0	1310.0	398.0	109.0	484.0

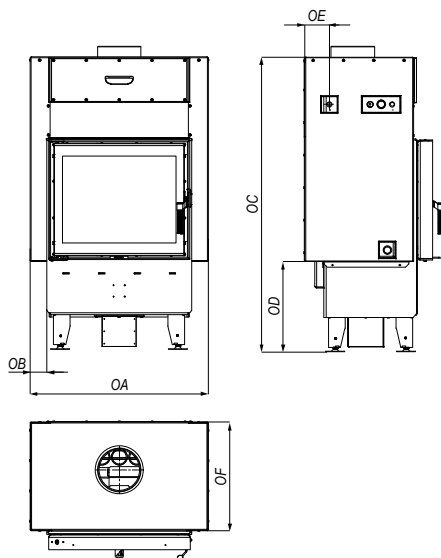

Picture 4.4 Projections with dimensions of DEFRO HOME NAVI fire-place insert in version with covers.

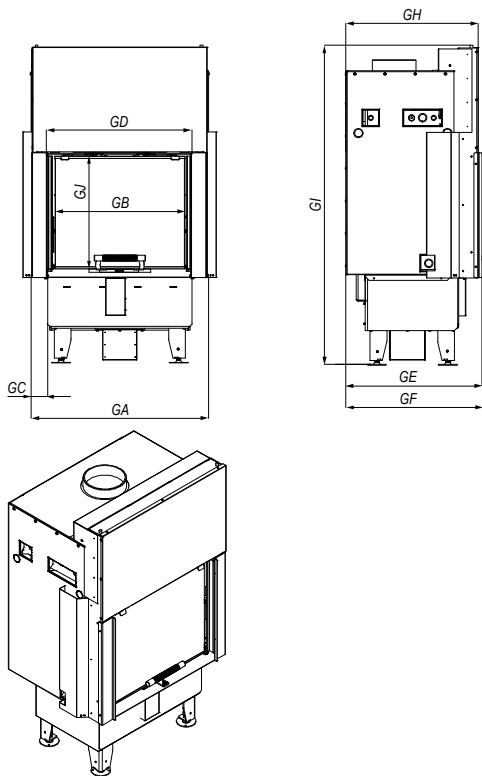

Picture 5 Projections with dimensions of DEFRO HOME NAVI G fire-place insert in version with covers.

Table 2. Dimensions of all models of the DEFRO HOME NAVI fire-place insert in the G version.

Type	dimensions [mm]								
	GA	GB	GC	GD	GE	GF	GH	GI	GJ
DH NAVI SM G	793.0	645.0	74.0	645.0	606.5	610.7	590.8	1424	500.0
DH NAVI ME G	958.0	810.0	74.0	810.0	606.5	610.7	590.8	1424	500.0

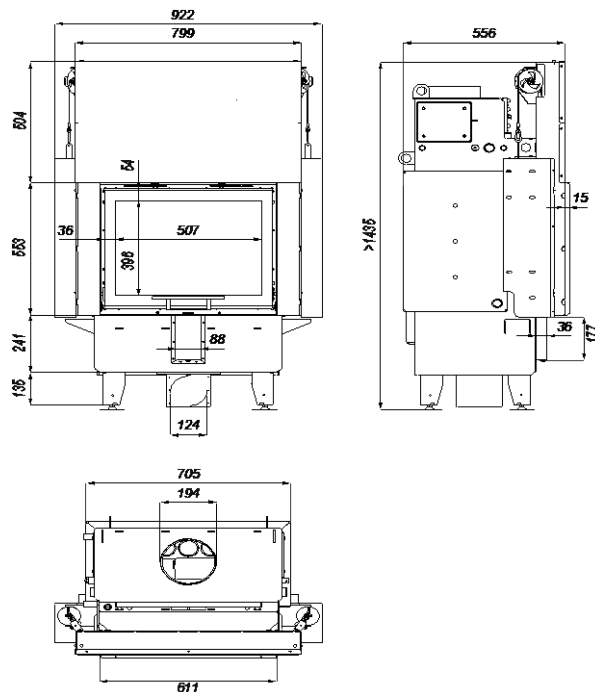

Picture 6 Projections with dimensions of DEFRO HOME NAVI SM G fire-place insert.

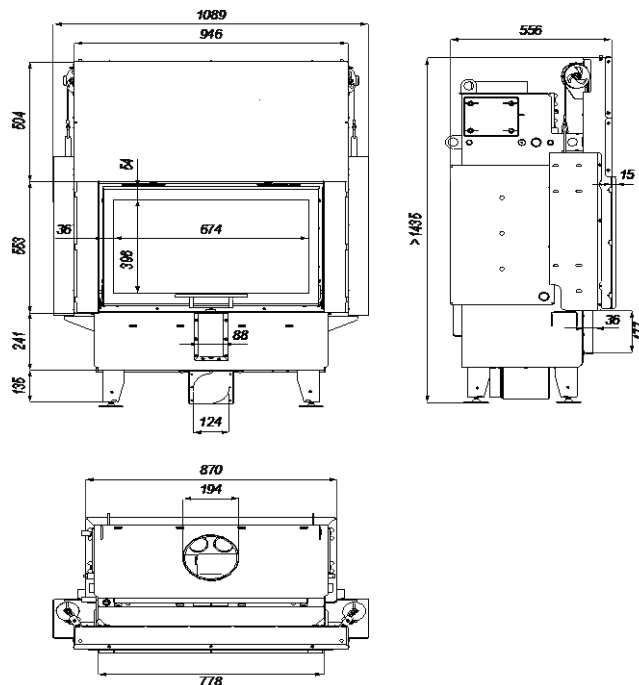

Picture 7. Projections with dimensions of DEFRO HOME NAVI ME G fire-place insert.

Table 3. Technical data for the DEFRO HOME NAVI fireplace inserts.

Specification / device type	unit	DEFRO HOME NAVI SM	DEFRO HOME NAVI ME
Nominal power	kW	14	17
Heat output of water cycle	kW	10	10
Max. permissible work pressure	bar	2	2
Heating power range	kW	11-17	13-20
Flue size	mm	200	200
Diameter of the central heating connectors	inch	1	1
Diameter of the connectors of the heat exchanger	inch	½	½
Diameter of the temperature sensor connector	inch	½	½
Diameter of the vent connector	inch	½	½
Efficiency	%	83.4	83.9
CO emission for 13% O ₂	% mg/m ³	0.0546 682	0.0534 668
Combustion temperature	°C	197	186
Weight ¹	kg	265±15	315±15
Water capacity	l	45	54
Flue gas stream for nominal power	g/s	13.9	17.2
Minimum draught at rated power	Pa	12±2	12±2
Fuel consumption	kg/h	4.0	4.8
Recommended single charge	kg	3-3,5	3,5-4
Maximum length of chunks	Mm	500	700
Fuel type	dry hardwood (max. 20% of moisture content)		
Heater type - with periodic combustion			

¹ Device weight depends on the selected design version and its equipment.

4.3. EQUIPMENT

The fireplace is delivered on a pallet, foil-wrapped and is fully assembled. Scope of delivery can include additional components and subassemblies, according to the order. The components which are standard equipment are specified in table REF_Ref7506578 \#0 4.

Table 4. Equipment of fireplace.

Standard equipment of fireplace	unit	Quantity
Operating manual for fireplace	pcs.	1
Ceramic lining of furnace chamber	set	1
DH sponge	pcs.	1

4.4. FUEL PARAMETERS

A fireplace insert is intended for the combustion of wood from deciduous trees (oak, hornbeam, ash, beech) with moisture content below 20% (wood seasoned in proper conditions for at least 2 years). The maximum length of chunks is given in table 3 It is allowed to use wood briquet.

It is not allowed to use wet wood (extensive contamination of fireplace and soot emission and decrease of energy efficiency of the stove).

It is forbidden to use all other fuels, min. coal, softwood from coniferous trees, wood from tropical trees, and any liquid fuels.

It is forbidden to combust all types of litter and wood wastes. Firing with inadmissible materials in the fireplace may result in damage to the fireplace and life and health hazard to the users (toxic flue gas from chemicals).



Use of bad quality fuel or incompatible with the above-mentioned recommendations would cause irregularities in the operation of the equipment and can lead to loss of warranty and decline of the liability for the product.

The fireplace is not a furnace intended for the combustion of wastes and forbidden fuels cannot be combusted in it.

Wood should be seasoned minimum of two (2) years. Firing with wet wood, with low calorific value, decreases the efficiency and has an adverse influence on dry stove lifetime.

It is not recommended to use softwood and resinous woods as fuel. It causes intensive smoke concentration and the necessity to clean the equipment and flue more often.

It is forbidden to combust coal, wood from tropical trees, chemical products, liquid fuels etc., e.g. oil, alcohol, petrol, naphthaline, laminated, impregnated boards etc., paper, cardboards, old clothes, wastes.

It is forbidden to exceed the recommended amount of charged fuel, because it may cause overheating of the equipment.

DEFRO R. Dziubela sp.k. does not accept liability for damages caused or improper burning of fuel if the fuel used is prohibited.

4.5. SPARE PARTS

To obtain information on the availability of spare parts for dry stove or inquiries about equipment servicing please contact with DEFRO Service Center or Authorized DEFRO Service.

	DEFRO R. Dziubela sp.k. Service Centre Ruda Strawczyńska 103a 26-067 Strawczyn		serwis@defro.pl
--	---	--	-----------------

5. TRANSPORT AND INSTALLATION

5.1. TRANSPORT AND STORAGE

The fireplace is delivered on a pallet, foil-wrapped and is fully assembled. It is recommended to transport the fireplace insert, in such packing condition, as close as the possible target location for installation, what will minimize the possibility of damage to the device housing.

All remaining parts of the packing should be removed in such a way that it will not pose any hazard to people and animals.



The fireplace is to be transported in a vertical position!

Appropriate lifts are to be used for lifting and lowering the fireplace insert. For transport, the fireplace insert is to be secured against moving and tilting on a vehicle's platform by means of belts, wedges and wooden blocks.

A fireplace insert is to be stored in a non-heated room, under a roof and with efficient ventilation.

Threaded sockets are protected with plastic plugs during transport. They should be removed during installation and replace with proper consumables.

Before the installation, you should check the completeness of the delivery, and its condition and **remove all transport protections!**

In a version with lifted doors (G versions) it is obligatory to check the arrangement of ropes with carabiners to ensure that they are led vertically on both sides of the unit, do not catch on the other components and do not jam the mechanism.



Before the first lifting of the doors in the G version fireplaces, you should absolutely remove the transport protections!

Failure to observe the above recommendation may cause problems in the operation of the guillotine mechanism and even lead to its damage. DEFRO R. Dziubela sp.k. shall not be liable for any damages resulting from failure to observe the recommendation.

5.2. WORKING ENVIRONMENT



The DEFRO HOME NAVI fireplace insert should be installed in compliance with the requirements of the currently applicable standards and legal regulations and the detailed regulations of the target country. In Poland, these conditions are regulated by the Regulation of the Minister of Infrastructure of 12 April 2002 on technical conditions which should be fulfilled by buildings and its location. (Journal of Laws no. 75 of 2002 item 690 as amended) and Polish Standard PN-EN 13229:2002 Inset appliances including open fires fired by solid fuels. Requirements and tests.

Fireplace insert should be installed in a suitable location allowing opening of the doors and carrying out regular maintenance works. The environment should be:

- adapted to operating conditions,
- equipped with a power supply 230V/50Hz,
- equipped with a suitable flue gas exhaust system,
- equipped with an external ventilation system,
- equipped with an earthing system with the CE certificate.

The design of the system should allow assembly and disassembly without damaging the system and the insert.

The correct setting of the insert is necessary to obtain a satisfactory heating level of the residential unit. Prior to assembly, it is necessary to select a suitable position for stove installation. Check minimum safe distances from materials susceptible to heat or inflammable materials such as load-bearing walls and other walls or wooden components, furniture etc. An exemplary installation of a fireplace insert is presented in picture 8.

Installation of the fireplace insert should observe the following safety rules:

- a minimum distance of 80 mm on the side and rear of the equipment body from the non-flammable materials.
- minimum distance 200 mm from the side and rear of the medium inflammable materials,
- minimum distance 800 mm from the front wall, where the medium inflammable materials cannot be located.
- objects made of highly inflammable materials should be located at a distance minimum of 2000 mm from the furnace

If it is not possible to maintain the above-indicated distances then you should apply process and building measures to avoid fire hazards. In the case of contact with a wooden wall or wall made of other inflammable material, it is appropriate to insulate flue gas discharge pipe.



In case of the floor made of inflammable materials, it is appropriate to prepare a plane protecting the floor and execute protection in accordance with the standards applicable in the given country.

The fireplace insert should be located on a substrate with suitable load-bearing capacity. In accordance with the Polish Standards each square meter of the floor slab in the single-family building should transfer load of 150 kg. If this condition is fulfilled the fireplace insert manufactured by DEFRO can be installed without needing to reinforce the floor slab.

Nonetheless, if you are not sure about the design of floor slab, where the fireplace insert is to be installed, you should absolutely contact with the building designer to reinforce the floor slab or execute a special structure distributing the weight on a larger area.



The flooring in the room, where the fireplace is to be installed, should be properly dimensioned, to maintain the load.

To ensure the correct operation of the fireplace insert you should ensure the suitable inflow of air required for combustion (it is appropriate to ensure approx. 40 m³/h) in accordance with the installation standards and standards applicable in the given country. The volume of the surrounding environment should not be less than 30 m³. You should assume that the combustion of 1 kg of wood requires ~8 m³ of air.

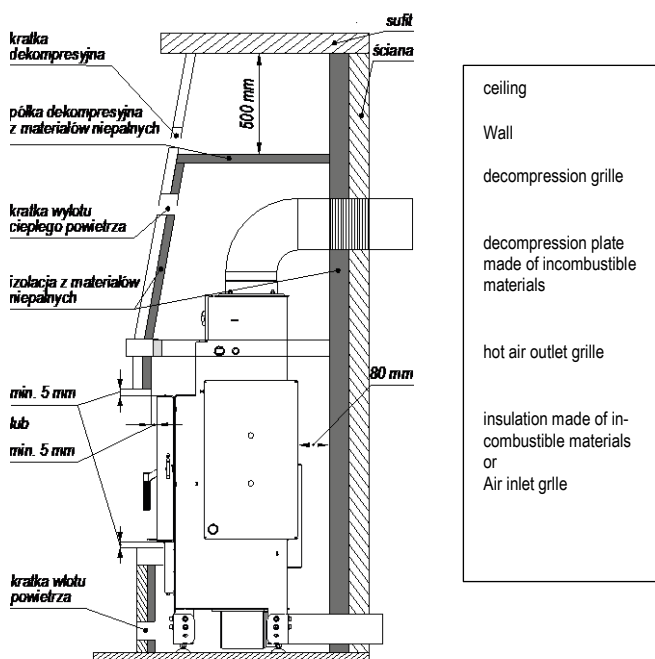
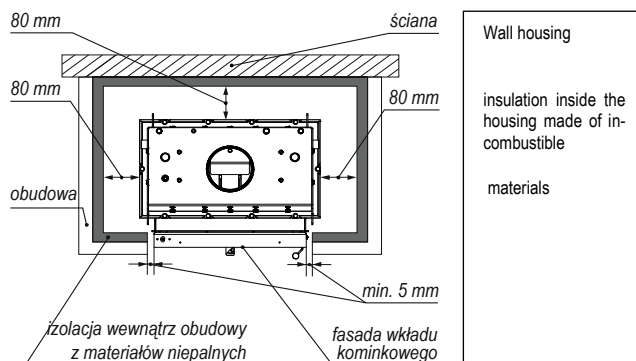

Picture 8. Exemplary installation of the fireplace insert.

ATTENTION!!!

Lack of expansion joint may be a reason for equipment damage. Installation of the fireplace inconsistently with the minimum distances from the system results in loss of warranty!!!



If several inserts are to be used in one room the air demand should be met for each insert.

Insert housing should ensure access of air necessary for ventilation, air circulation in the housing. In the bottom part of the installation (under the insert) it is appropriate to ensure air supply openings ensuring air supply for combustion. To ensure the correct discharge of hot air from the hood you should install exhaust openings ended with ventilation grilles. These openings should be made in a way ensuring that they cannot be plugged. They should be ended with grilles.

It is required to keep the expansion joint around the door frame of the fireplace, that is minimum distance not lower than 5 mm. During the designing of the system, it is required to consider also possible assembly of a frame (which is an optional component), to ensure that after its assembly the minimum expansion joint between the frame and the system will be kept.

It is indicated to use a bigger expansion joint for the fireplaces with lifted doors (G version), in particular between the front of the body and the installation (it should be from 20 to 30 mm). It will contribute to the longer and trouble-free operation of doors mechanism.

The active area of the grille should be selected correspondingly to the power of the insert. It is assumed that it should equal 40 - 60 cm² per 1 kW of power of the insert. Recommended active surfaces:

- fireplace insert power to 10 kW - grille cross-section min. 500 cm²,
- fireplace insert power to 15 kW - grille cross-section min. 700 cm²,
- fireplace insert power over 15 kW - grille cross-section min. 800-1200 cm² and more.

Air can be supplied from adjacent rooms, provided that they are equipped with external air supply and they are not intended for a bedroom and bathroom, and where fire hazard is not present, for example: garages, woodsheds, inflammable materials storage. You should absolutely observe the recommendations of the applicable standards.

The temperature over the insert, inside the hood, is very high. Therefore it is necessary to install a decompression relief plate inside the hood, in a distance ~40cm from the ceiling of the room. It prevents heating of the ceiling in the room, and heat losses and forces the installation of exhaust grilles below it emitting the heat from the relief chamber over the insert. Relief grilles are installed alternately on both sides of the housing - below and over the relief plate.



Before installation of the fireplace insert with lifted doors (G versions) you should check the correctness of operation of the lifting mechanism and in particular, you should check the arrangement of ropes with carabiners.

5.3. HOT AIR DISTRIBUTION SYSTEM

5.3.1. GRAVITY SYSTEM FOR HOT AIR DISTRIBUTION

The DEFRO HOME NAVI ME fireplace insert gives back approx. 40% of the power to the environment when the air is being heated. In the case of heating of small areas, e.g. room where the fireplace insert is installed, and adjacent rooms, you should select a gravity system for air distribution, when the hot air will rise upwards to the chamber in heating ducts by way of thermal lifting forces.

Using of the gravity system you should use properly insulated and short (not exceeding 3 m) distributing ducts. For this system, it is not recommended to distribute hot air to too many rooms. Also, use of too long pipes (over 3 m from the flue) increases resistance and decreases air flow velocity which causes that gravity flow is not effective.

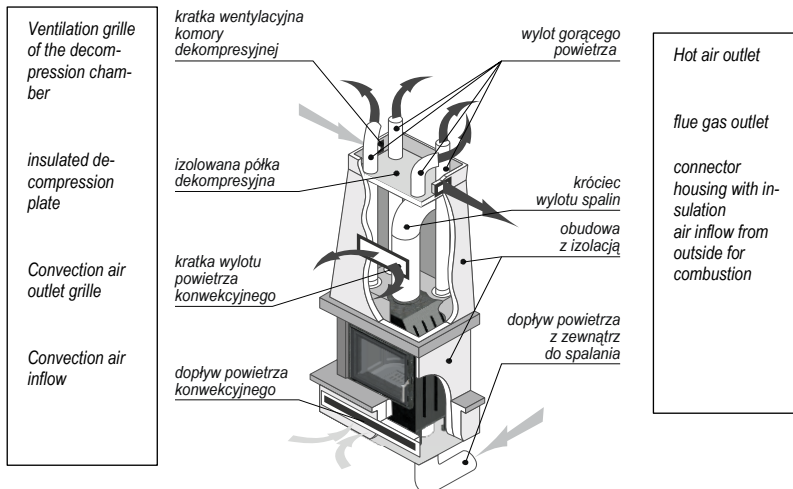

Picture 9 Hot air distribution system.

5.3.2. FORCED SYSTEM FOR HOT AIR DISTRIBUTION

The application of a forced system for hot air distribution (DGP) requires the installation of an air supply device (turbine). It sucks hot air heated by the fireplace insert and forces it to all branches of the system. In such a case you should use a pipe connecting the distributor with air supply unit with the biggest possible cross-section and the smallest possible length



Installation of the DGP system should be entrusted to a specialized company, which will check heat demand for the given area and will correctly design the connection system and arrangement of the individual parts.

5.4. CONNECTION TO EXTERNAL AIR INTAKE

Room, where the fireplace insert is installed, should be equipped with the inflow of air in the minimum amount required for the correct combustion process and for room ventilation. This can be done by executing fixed vents in the wall directed to the outside or through independent or common ventilation ducts.

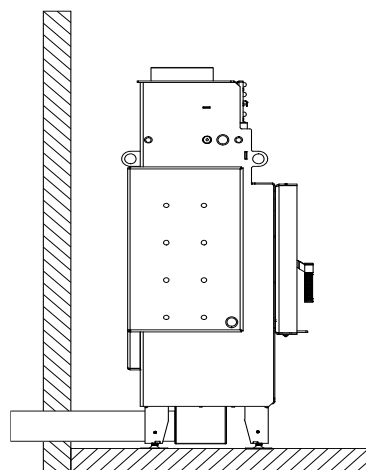

Picture 10 Connection of fireplace insert to the external air intake.

The external wall near the stove should have through the opening, protected with a grille on the internal and external side, for this purpose.

Furthermore, the air intake should be:

- directly connected with the room, where the fireplace insert is to be installed,
- protected with grille, metal net or suitable cover not restricting minimum cross-section,
- located in a way preventing plugging it,

- located with consideration of proper distances preventing swirling of air (e.g. with respect to the windows).

5.5. INSTALLATION TO THE FLUE

The fireplace insert should be connected to the individual flue. The size of the chimney draught should equal:

- minimum draught – 6 ± 1 Pa,
- medium, recommended draught – 12 ± 2 Pa.
- maximum draught – 15 ± 2 Pa.

During the execution of opening for flue gas discharge pipe, you should consider the possible occurrence of inflammable materials. If the opening will pass through the wooden wall or wall made of material sensitive to heat then you should obligatorily maintain the minimum distance from flammable material (value given on the certification label of the pipe), with possible additional insulation using proper materials (thickness 1.3 - 5 cm, heat conductivity min. 0.07 W/m °K).

As an alternative it is recommended to use insulated industrial pipe, which can be also used outdoors, to avoid the occurrence of condensate.

For correct operation connector between the fireplace insert and flue or smoke duct should be executed acc. to the below recommendations:

- horizontal sections should have a minimum slope of 3% towards the top,
- length of the horizontal section should be minimum and should not exceed 2/3 metre,
- a number of changes of directions, inclusive of the use of the "T" component, should not exceed 4.

A chimney or individual smoke duct should meet the following requirements:

- be resistant to combustion products, water-proof and suitably insulated, in compliance with conditions of use,
- be made of materials resistant to normal mechanical stresses, heat, the action of combustion products and possible condensate,
- be vertical with the change of axis direction not exceeding 45°,
- be adequately separated with void space or suitable insulation from combusted and inflammable materials,
- have preferably circular internal cross-section: square or rectangular cross-section should have rounded corners with a radius not smaller than 20 mm,
- internal cross-section should be constant, free and independent,
- have a rectangular cross-section with the maximum ratio between two sides equal to 1.5.



It is forbidden to use mechanical exhaust ventilation when the insert is not connected to external air inlet. The fireplace insert should not be used if the chimney draught is too low.

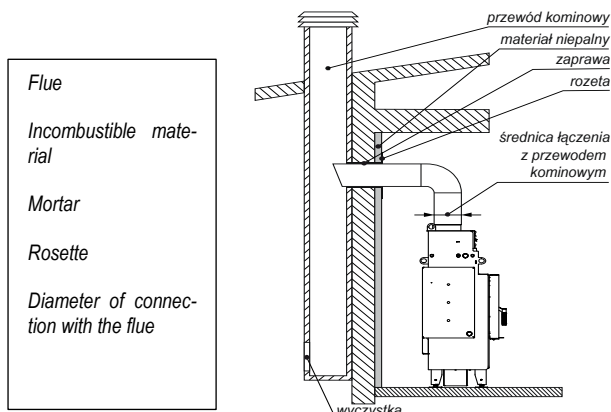

Picture 11. Connection of fireplace inserts to a flue.

5.6. INSTALLATION IN CENTRAL HEATING SYSTEM

The DEFRO HOME NAVI fireplace insert is equipped with a water system allowing operation in the central heating system. The water system is equipped with a protecting heat exchanger (cooling coil), so it is possible to install it both in an open and closed system.

The connection of the chimney's water system should be made in compliance with the applicable standards and regulations and in particular with the following documents:

- The Regulation of the Minister of Infrastructure of 12 March 2009 on technical conditions which should be fulfilled by buildings and its location.*
- Standard PN-EN 12828:2014 - Heating systems in buildings - Designing of water central heating systems;



The central heating system is to meet requirements specified by the Polish Standard PN-91/B-02413 on the protection of open system water heating devices and pressure vessels.

In the case of installation of the fireplace in a country other than Poland it is obligatory to apply relevant requirements and standards of this country.

Before installation of the fireplace insert you should make a test connection of the water system to the central heating system and then enter the working pressure in the system to check its tightness. A fireplace insert should be embedded when all leaks in the water systems have been excluded.

Pictures 12 and 13 present connection diagrams for the water system of the DEFRO HOME NAVI fireplace insert in the heating system.

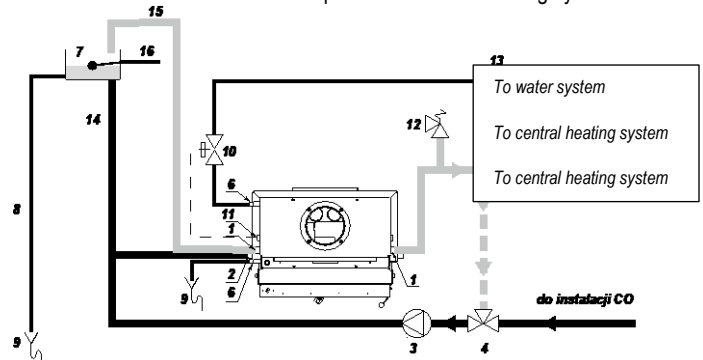

Picture 12 Diagram of exemplary connection of water system of the DEFRO HOME NAVI fireplace with the heating system in the open system.

1 – hot water outflow socket, 2 – cold water inlet socket, 3 – circulating pump, 4 – mixing three-way thermostatic valve, 5 - non-return flap valve, 6 – sockets of protecting heat exchanger, 7 – diaphragm expansion vessel, 8 – filling and emptying fittings, 9 – sewage system, 10 – thermal protection of outflow, 11 – thermostatic valve sensor, 12 – pressure safety valve, 13 – filter.

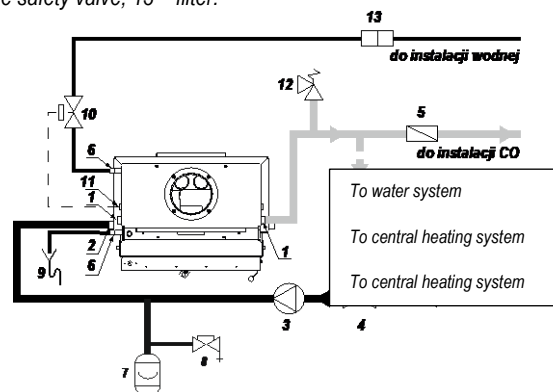

Picture 13. Diagram of exemplary connection of water system of the DEFRO HOME NAVI fireplace with the heating system in the closed system.

1 – hot water outflow socket, 2 – cold water inlet socket, 3 – circulating pump, 4 – mixing three-way thermostatic valve, 5 - non-return flap valve, 6 – sockets of protecting heat exchanger, 7 – expansion vessel with float, 8 – overflow pipe, 9 – sewage system, 10 – thermal protection of outflow, 11 – thermostatic valve sensor, 12 – pressure safety valve, 13 – filter, 14 – expansion pipe, 15 – safety pipe, 16 – power supply from water pipe.

The water system in the DEFRO HOME NAVI fireplace insert is equipped with two supply and two return sockets so it is possible to select hook up points to the central heating system. For correct and effective operation of the water system locations of connection to the central heating system should be in crossed arrangement, that is central heating supply to the left socket and return from central heating to the right socket or central heating supply to the right and return to the left.

Thermal protection of the outflow (10) is a valve, which based on the temperature signal from the sensor (11) will be opened if the safe operating temperature of the water system will be exceeded. Water from the water system flowing through the heat exchanger cools the water system down decreasing water temperature from the central heating system and then it is discharged to the sewage system.



- **Protecting heat exchanger (protecting coil pipe) should be connected to the water supply system ensuring continuous water inflow, also if the electric power is not available.**
- **Protecting heat exchanger is intended only for emergency heat collection and should not be used as a flow, utility water heater.**

To ensure the correct operation of the water system it is necessary to meet the condition that the temperature of the water returning from the CO system is not lower than 50 °C (dew point for wood with moisture content 20%). This is connected with steam condensation on cold walls of the fireplace insert (so-called insert's sweating), which leads to a decrease in lifetime and heating efficiency. This phenomenon can be avoided by applying various methods, e.g. by setting higher temperature of water in the water system and adjustment of temperatures in heated rooms using thermostatic valves or using mixing systems. The function of thermal protection against a drop of return water temperature below the dew point is implemented by a mixing three-way thermostatic valve (4), which based on the measured value of the installed temperature sensor opens a corresponding valve with hot water mixing it with cold water from return - in case of examples on the pictures 12 and 13.



It is required to install thermal protection in the system preventing the return of water with temperature below the dew point (50 °C). Lack of such protection leads to a dramatic decrease in heating efficiency and damage to the equipment. Failure to observe this recommendation may cause loss of the warranty.

It is required to installed a safety valve (12) in the closed system. Its task is to protect the water system and installation against exceeding of maximum allowable working pressure. The valve should be factory set to 2.0 bars and should prevent exceeding of maximum operating pressure by not more than 10%.

The valve should be installed as close heat source as possible: it can be installed directly in the free supply socket or on the pipe supplying the installation, in an easily accessible location.

If the allowable pressure is exceeded the safety valve discharges excess of water and steam through the discharge pipe decreasing pressure in the system. Therefore, you should ensure safe water and steam outflow from a safety valve (e.g. to the sewage system).



It is recommended to use safety fittings, a so-called safety unit, which consists of a safety valve, manometer and vent.

Connections of the water system with the central heating system should be made using threaded or flanged joints.



- **Installation of the water system of fireplace insert by welding results in loss of warranty!!!**
- **Fireplace insert installation should be carried out by a person or company with suitable qualifications and authorizations.**
- **It is in the user's interest to look after that installation is made in accordance with the regulations in force and that installing company gives a warranty for correctness and good quality of workmanship what should be confirmed by a stamp and sign on the warranty card of the boiler.**
- **The hydraulic system of the water system of the fireplace insert should be made in compliance with the currently applicable standards and regulations. All national and local provisions should be met!**

6. USAGE AND OPERATION

6.1. FILLING WATER SYSTEM WITH WATER

Make sure that the central heating (CO) system is correctly filled with water, which should be clean, clear and without any admixtures prior to start up. Filling a water system with water should be carried out only when it has been cooled down.

Water quality has an essential influence on the life of the water system and the whole central heating system Water should have the following parameters:

- pH reaction:
 - 8.0 ÷ 9.5 - in steel and cast iron systems;
 - 8.0 ÷ 9.0 – made of copper and mixed materials steel/copper;
 - 8.0 ÷ 8.5 - for systems with aluminum radiators;
- total hardness < 20 °f,
- free oxygen content <0.1 mg/l, recommended <0.05mg/l,
- chlorides content <60mg/l.



Before connecting the fireplace with the water system to the old central heating system user should carry out flushing to remove sludge remaining in the radiators and pipes.

Fill the system with water prior to firing up of the fireplace. Filling with water should be carried out through the return socket of the water system or installed fixture for filling and discharging (8, picture 13). This process should be carried out slowly in order to deaerate the system.

To check if the system has been filled with water, the straight-run valve located on the signaling pipe should be opened for a few seconds. Continuous water outflow means the system has been filled in correctly. Any water refills should take place in the boiler's inactivity period.



- **It is unacceptable and strictly forbidden to refill water during the fireplace insert's operation, especially when the temperature as high as it may lead to its damage or crack.**
- **Water can be refilled only due to its losses by evaporation. Other decrements such as system leakage are inadmissible as they may lead to the**

creation of boiler scale resulting in permanent damage to the water system.

6.2. INTRODUCTORY REMARKS

Prior to installation of the fireplace insert you should make several test fire ups. During test firing up you should check the operation of the chimney damper and the other mechanical systems of the equipment.

During the initial period after installation, the fireplace insert should be operated with power equal to approx. 30% of rated power and increase temperature gradually. It allows gradual removal of internal stresses preventing the occurrence of thermal shocks. Furthermore, such a method of operation improves the durability of the insert.

The fireplace insert is subject to expansion and shrinkage during the warming and cooling down stage what may cause slight squeaks. This is absolutely normal phenomenon because the structure of the fireplace is made of rolled steel and this phenomenon shall not be considered as a defect.

Do not stay near the stove during several first fire ups. It is also required to vent the room. Smoke, the odor of paint, silicone and other materials used for the execution of the installation will disappear after several fire ups. However, we remind them that they are not harmful to their health.



It is good practice to ensure efficient ventilation during first firing-up because a small amount of smoke and odor or paint and other materials will be emitted from the fireplace insert.



Do not use a non-installed fireplace insert. Test firing up is an exception.

6.3. FIRST START-UP AND OPERATION



Before first start-up it is obligatory to seal the equipment in accordance with the enclosed manual.

Firing from the top is a recommended method of firing of the fireplaces. Prior firing up you should set a slider of air inflow adjustment to maximum opening (marking on the handle, presented in picture 14). Then, open the doors of the fireplace insert and place fuel on the grate as follows: place split thick chunks at the bottom, then another layer of thinner chunks. Place small slivers at the top, where you may additionally place eco-friendly kindling.

It is important to ensure free space (approx. 1 cm) between each of the chunks.

The single fuel charge is given in table 3.



It is forbidden to use other materials than described in this manual for firing up, in particular flammable chemicals such as: oil, petrol, solvents and others.

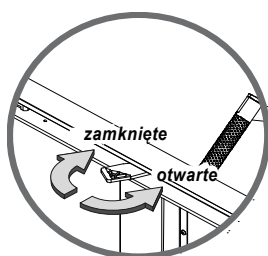

Picture 14. Setting of a slider for air inflow adjustment

If the draught in the chimney is not sufficient then you may unseal it by the minimum opening of the fireplace doors during the initial firing up stage. If the fireplace insert is not supplied with the air from outside

then it is required to supply a sufficient amount of the air by opening a window in the room where the equipment is located.

You should use only hardwood (recommended beech, oak, hornbeam, birch), preferably debarked, of low moisture content (below 20%).

During combustion, the doors should be opened only when the fuel is being added. Recharging should be made only when only an ignition layer, in the form of glow, remains in the furnace. Before adding the wood, it is required to spread the remaining layer of glow and refill the combustion chamber with wood - in accordance with picture 15. The intensity of the combustion process should be set with the "air inflow adjustment slider". The correct flame should have a light-yellow color and a length of approx. 20-40 cm, depending on the power of the boiler, after approx. 2-3 minutes from charging. If there are problems to obtain the correct flame in a short time - you should increase the opening of a flow damper and set the target position after firing up.

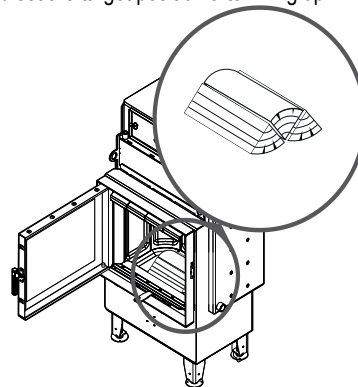

Picture 15. Method of fuel arrangement



Never stand in front of the fireplace insert's door while opening. Burn risk.

Odor of paint from the body will be released during first several hours of combustion. This is completely normal. You should strongly vent the room at that time. Check the tightness of joints once again when fuel is completely burned out and equipment has been cooled down.



Housing components will be very hot during operation. You must exercise caution.

For fireplaces of higher power (ME) there can be a momentary draw back of smoke into the room during the opening of the doors. It is normal for such types of fireplaces. If the amount of such smoke is considerable and lasts for a whole duration of doors opening then it is absolutely required to check possible causes acc. to the guidelines given in chapter 8.

You should control the level of filling of the container with ash. Overfilling of container results in lack of cooling of the grate and limits air supply for combustion. To empty the container you should damp a fireplace, close inflow of air for combustion and wait until the surface and parts of the fireplace insert cools down. Then open the doors of the insert, remove the grate and take out the container. Remove ash from the container and re-install in the body of the insert. It is recommended to empty ash container prior to each successive start-up of the equipment.

6.4. DAMPING

Damping is executed by the closing inflow of primary air. In such a case you should wait until the fuel completely burns out in a natural way.

If it is necessary to quickly damp a flame you should charge the furnace chamber with dry sand or ash. It is not allowed to damp a flame by pouring it with water because it may damage components of the equipment.



After a longer break in equipment's operation, you should check the flow capacity of the flue.

6.5. LOW-TEMPERATURE CORROSION

Fireplace inserts with a water system should be operated with differences between supply and return temperatures within the range of 10-20°C and return water temperature not smaller than 50°C. While operating, if the central heating water temperature is below 60°C, water vapor contained in flue gas condenses on the fireplace's walls. During the initial period of operation, the above-mentioned condensate may leak from the fireplace.

Longer operation at lower temperatures may lead to corrosion resulting in shorter water system life. Hence, it is not recommended to use the fireplace insert if the temperature of the water supplying the central heating system is below 60°C.

To ensure the proper, failure-free and effective operation of the fireplace insert it is recommended to use it with the water system, on 80% of its rated power and with a temperature of water in the boiler not lower than 65 °C. It is also recommended to install a mixing valve.



To ensure the correct operation of the fireplace insert with water system it should be protected against the corrosion caused by return of water with temperature below the dew point from central heating system. Temperature of return water should have min. 50 °C.

If the temperature of water supplying central heating system is below 60°C, water system operation leads to intensified precipitation of tarry substances from burnt fuel resulting in deposits of tar sludge in the heat exchanger and flue, reduces efficiency of the fireplace insert and, in the first instance, leads to the risk of soot ignition in the chimney.

7. CLEANING AND MAINTENANCE



All operations related to cleaning of all components should be carried out when the fireplace is completely cold. It is required to use protective gloves.

It is forbidden to clean the equipment (all painted components and gaskets) using chemicals, liquids and moist cloths, towels, industrial wipers etc. Discolorations, sources of corrosion may occur if the mentioned rules are not observed and they are not covered by the warranty.



It is a good practice to ensure good ventilation of the room during the cleaning of the fireplace.

7.1. BASIC OPERATIONS AND CLEANING BY THE USER.

Any service and maintenance works are to be carried out with meticulous care and only by adults familiarized with this manual. The fireplace insert should not be cleaned in the presence of children.



Any service and maintenance works are to be carried out with meticulous care and only by adults familiarized with this manual. The dry fireplace insert should not be cleaned in the presence of children.

Protective gloves, glasses and headgear are to be worn to operate the equipment.

7.2. CLEANING BEFORE EACH STARTING

Prior to every successive start-up of the equipment, the ash container should be cleaned and emptied, handling the ash with due care. Remove grate, then ash container (picture below) using handles, and remove the remaining dust. Dust can be removed using a vacuum cleaner only if it is completely cold. Use a vacuum cleaner adapted to removing the particles of specified size for this purpose.

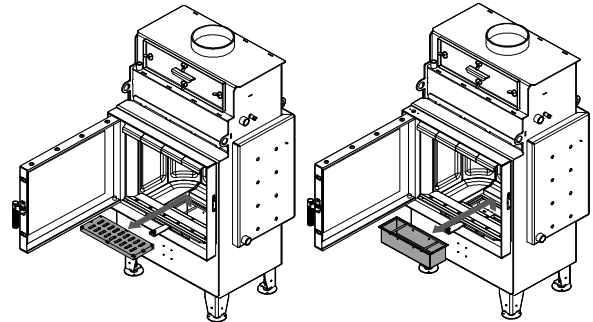

Picture 16. Removal of grate and ash-pan.

Re-install the ash container below the grate after the cleaning, making sure that its position is correct.

7.3. WINDOW PANEL CLEANING

The window panel may be cleaned only and exclusively when the fireplace does not operate and is at room temperature.

Before each cleaning of the glass pane, it is required to protect the painted components and surfaces, and gaskets against flooding, because it has an impact on quicker wear and tear of the components.

We recommend using only the DH sponge to clean the glass panes. We do not recommend using any liquid for cleaning of glass panes or chemicals. The absence of protection of the cords surrounding the glass panes causes loss of their properties, soaking with chemicals and reactions with high temperature that results in damage to the glass pane.

The sponge is intended only to clean the glass panes, it should not be used for gaskets or metal parts. It is not suitable for cleaning of glass panes with pyrolysis. The sponge may be used several times, depending on the degree of soiling of the glass pane. Use the gray side for cleaning and brush it off each time after use.

Do not use products that may scratch the glass pane. The ash may contain substances that will scratch the glass ceramics.

The window panel in the DEFRO HOME NAVI fireplace insert in the G version should be cleaned when doors are in a hinged position. Fireplaces with guillotine doors are equipped with locks in the upper part of the door frame (picture 17).

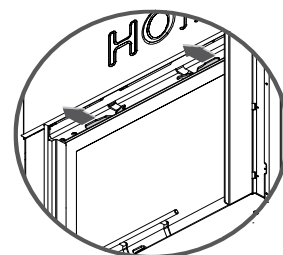

Picture 17. Location of locks allowing opening of the doors in hinged position for DEFRO HOME NAVI G.

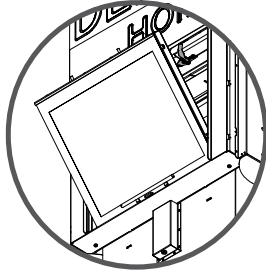

Picture 18. View of the doors of the DEFRO HOME NAVI G insert in lifted position.



It is forbidden to use abrasive agents or materials, because they may scratch the glass surface.

It is forbidden to use chemical cleaning agents, because in the case of contact with such agents they may cause damage to the components of the fireplace insert, that is print on the glass pane, glass pane, gaskets, painted surfaces.



Do not open doors to clean the window panel during the operation of the fireplace. Cleaning of window panel is possible only when the equipment is cold.

Opening of guillotine doors in hinged position should be used rarely, only when it is necessary during occasional cleaning of window panel or other service works.

7.3.1. DOORS/GASKETS

Abrasive surfaces of doors and closing mechanisms should be occasionally lubricated with graphite grease. Carry out inspection and cleaning of the whole stove prior to each heating season. Pay special attention to the condition of gaskets, and replace them if necessary.

7.3.2. FURNACE CHAMBER

Clean the furnace chamber of the insert periodically, depending on moisture content and type of wood used.

7.3.3. FLUE

In compliance with applicable regulations, you should clean the flue twice (2) a year. The flue should be cleaned by a chimneysweep company and this fact should be documented in this manual.



Flue gases coming out of the blocked chimney are dangerous. Chimney and connector should be kept clean. They should be cleaned before each heating season.



After a longer break in equipment's operation, you should check the flow capacity of the flue.

7.3.4. WATER SYSTEM

At least twice a year you should carry out inspection and maintenance of all components ensuring safe operation of the water unit and central heating system, including the safety valve and thermal safety valve. If a longer break in operation of the fireplace insert is planned and if it is possible that the temperature will fall below 0°C then you should discharge water from the central heating system to prevent freezing of water in the system and its damage. Check filling of the central heating system with water prior to each start up after a longer break in operation of the fireplace insert.



At least twice a year you should carry out inspection and maintenance of safety valve, thermal safety valve and other components ensuring safe operation of the water system and whole central heating system.

- **Check the level of water in the DEFRO HOME NAVI fireplace insert after each longer break in operation.**

7.4. PERIODIC INSPECTION BY AUTHORIZED SERVICE

After the heating season, it is necessary to clean the chamber through which flue gas is flowing. This cleaning is obligatory and is intended to remove all combustion residues.



Periodic inspection of the equipment should be carried out only by qualified manufacturer's service.

7.5. DISASSEMBLY OF DOORS FOR BASIC VERSION

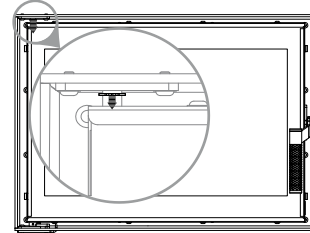

1. Slide protecting ring downwards maximally.

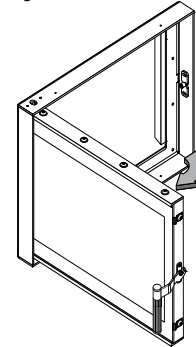

2. Open the doors.

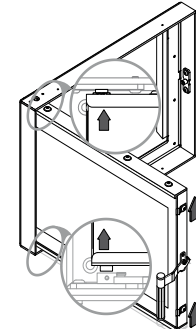

3. Lift the doors fully upwards to remove bottom pin of the hinge from a sleeve.

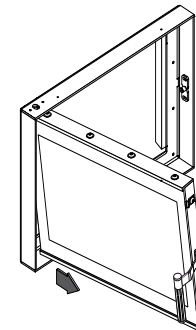

4. Tilt doors from bottom to outside to ensure that the bottom pin of the hinge is outside the frame.

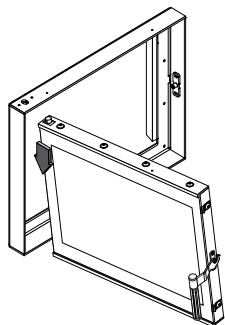

5. Lower the doors to ensure that the upper pin of the hinge leaves the upper opening of the frame and remove the doors

7.6. DISASSEMBLY OF WINDOW PANEL FOR BASIC VERSION

It is possible to disassemble the window panel after the doors have been disassembled. The best way is to disassemble the window panel when the doors are in a horizontal position (e.g. when such doors lie on the table). Version with side window panel: first, remove the front window panel and then the side window panel.

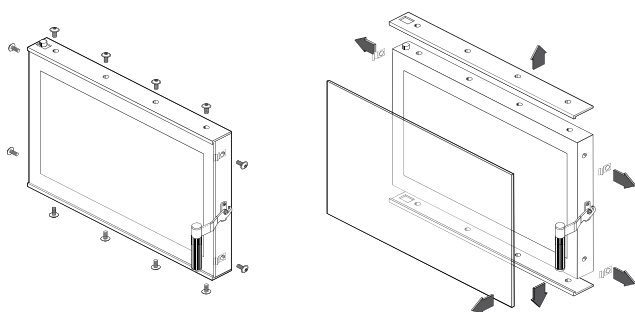

Picture 19. Window panel dismantling from doors.

7.7. DISASSEMBLY OF DEFLECTOR

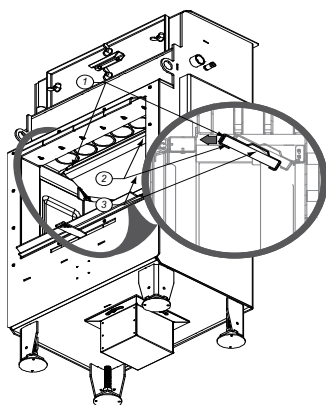

1. Move deflector (3) with its cover (1) and supporting beam (2) to the front.

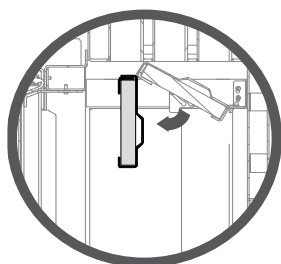

2. Rotate whole deflector set by 60°.

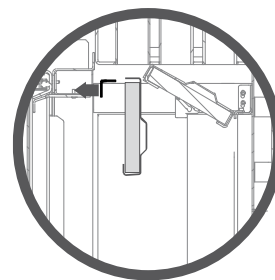

3. Remove and then slide supporting beam to the front while holding a deflector with its cover.

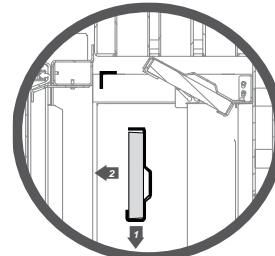

4. Lower deflector with cover and remove unit.

7.8. DISASSEMBLY OF CERAMIC TILES

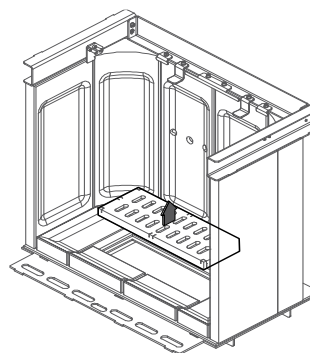

1. Remove grate.

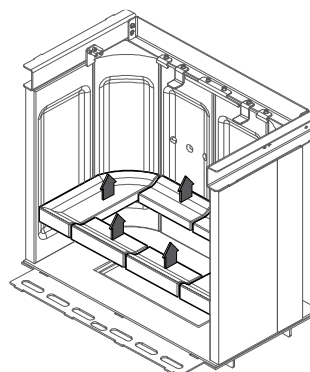

2. Remove plates laying on the floor of the insert.

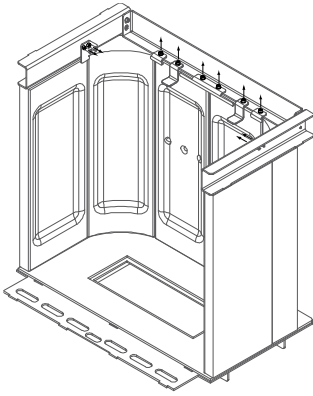

- Remove screws fixing the deflector tag and fixing of vertical ceramic plates

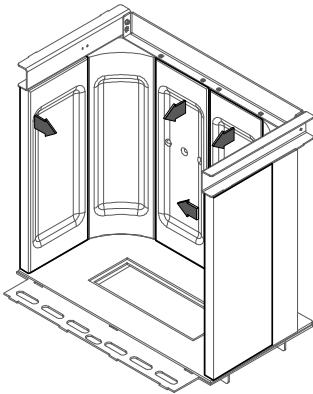

- Remove side plates first.

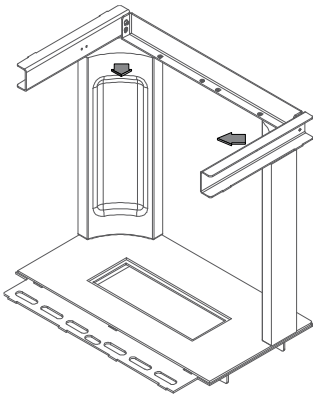

- Remove corner plates at the end.

7.9. SHUTTING THE STOVE DOWN

It is recommended completely shutdown the fireplace and clean the equipment when each heating season is finished.

8. TROUBLESHOOTING

Some anomalies indicating irregularities in operation can occur during the operation of the equipment. It can be caused by incorrect installation of the equipment without observation of the applicable building regulations or provisions of this manual or by external causes e.g. natural environment.

Below you will find the most frequent causes of incorrect operation of the equipment with their solutions.

Smoke draw back when the doors are opened:

- too rapid opening of the doors (open the doors slowly);

- if a chimney damper has been installed as a chimney draught regulator - open the chimney damper each time when the doors are opened;
- insufficient air inflow to the room, where the equipment is installed (ensure proper ventilation in the room or supply air to the combustion chamber in compliance with guidelines in the manual);
- atmospheric conditions: low pressure, mists and precipitation, sharp changes in temperature;
- insufficient chimney draught (carry out chimney sweep inspection of the flue).

Insufficient heating or damping:

- too low amount of fuel in a furnace (charge furnace in compliance with the manual);
- the too high moisture content of wood used for combustion (use wood with moisture content <20%) large part of obtained energy lost in water evaporation process;
- too low chimney draught (carry out chimneysweep inspection of the flue).

Insufficient heating despite good combustion in combustion chamber:

- low calorific "soft" wood (use wood as recommended in the manual);
- the too high moisture content of wood used for combustion (use wood with moisture content <20%);
- too fragmented wood, too thick chunks of wood;

Excessive contamination of window panel:

- low intensity of combustion (combustion with very small flame, use only dry wood as fuel);
- using resinous softwood as a fuel (use dry hardwood as a fuel
- foreseen in the insert operating manual).

Too high temperature in the water system or too high difference of temperatures between water system and water in the central heating system:

- circulating pump in the central heating system does not operate (pump switched off, damaged or power failure);
- air lock of the central heating system;
- closed cut-off valves.



Correct operation can be disturbed by atmospheric conditions (air moisture content, fog, wind, atmospheric pressure) and sometimes by closely located high facilities.

In case of repeated problems, you should turn to chimneysweep company to confirm the reason for such condition and to indicate the best solution for the problem.

9. MEASURES IN CASE OF FIRE IN THE FLUE /SOOT IGNITION/



Systematic cleaning of smoke ducts should be performed to prevent soot ignition in the chimney.

Soot ignition in the chimney is the burning of particles deposited inside the chimney (flue) channels; the deposits are formed in the

course of heating equipment's operation and were not cleaned by chimney sweeps. In a case of soot fire in a chimney the following recommendations should be observed:

- call Fire Brigade at 998 or 112, give information about what is happening and give detailed directions on what is happening and how to get to the given building;
- damp a fire in the chimney by closing the inflow of cold air to the furnace chamber;
- close the fireplace's door and cleaning holes tightly to cut off air supply (due to lack of air the fire will eventually stop);
- check the whole chimney channel for any cracks which might result in fire spreading to the rooms;
- prepare fire quenching means, e.g. a fire extinguisher, a fire blanket, a hose connected to the water system, water in a container;
- make rooms and necessary information available to the Fire Brigade.



It is strictly forbidden to pour water into the chimney - risk of blowout.

Utight chimney channels can be source of burning sparks or very hot flue gas, including insensible carbon monoxide.



Chimneysweep should be called after soot fire in the chimney to perform cleaning of ducts and to inspect their technical condition.

10. REMOVAL DUE TO WEAR-OUT

A fireplace insert is made of materials neutral to the environment. After worn out of the insert parts connected with screws should be disassembled by unscrewing and welded parts must be cut. Elements of a stove are subject to standard waste disposal, mostly as steel scrap. Take safety precautions during disassembly of the insert by using appropriate hand-held and mechanical devices as well as personal protective equipment (gloves, clothes, apron, glasses, etc.).

11. REMARKS ON FIREPLACE INSERT USAGE



The following rules of safe operation of the fireplace inserts should be strictly observed and introduced.

- 1) The fireplace insert can be used only by adult persons, who have familiarised themselves with this operating manual and have been trained in the scope of usage.
- 2) It is forbidden for children to be in the neighborhood of the fireplace insert without adults.
- 3) Flammable liquids must not be used for torching the fuel; only solid fuel (e.g. tourist), paper can be used etc.
- 4) Flammable materials must not be placed on the fireplace insert and in its vicinity.
- 5) During the fireplace insert's operation, the heating water temperature should not exceed 90°C.
- 6) It is forbidden to damp a fire in a furnace with water.
- 7) It is forbidden to use a fireplace insert with a cracked window panel.
- 8) You should use the fuel recommended by the manufacturer.
- 9) Never stand in front of the doors while opening. Burn risk.
- 10) While removing ash from the fireplace insert flammable materials cannot be located closer than 1500 mm. Ash is to be put into heat-resistant containers with a lid.
- 11) After the heating season has finished, the fireplace insert and smoke duct are to be precisely cleaned.

- 12) Point corrosion spots are allowed because they do not impact the correct operation of the equipment and do not reduce its performance. They may occur as a result of incorrect storage of equipment (e.g. in rooms of high moisture content).
- 13) A phenomenon of condensation of water steam - condensate, may occur during operation.

12. PRODUCT WARRANTY TERMS AND CONDITIONS

- 1) Placing warranty statement, which contents correspond to the provisions of this document, the Guarantor - manufacturer of the product - DEFRO R. Dziubela spółka komandytowa, Ruda Strawczyńska 103 A, 26-067 Strawczyn, entered in the Register of Entrepreneurs of the National Court Register by the District Court for the capital city of Warsaw XII Commercial Division of the National Court Register, under the number KRS 0000620901, NIP: 9591968493, National Business Registry Number [REGON]: 363378898, gives the Purchaser a warranty for the sold product on the terms and conditions specified below.
- 2) The guarantee refers to a fireplace insert type with serial number (subject of agreement - fireplace insert) under the condition that the product has been fully paid. Due to suitable, proven and unified standards of sales the warranty covers only products purchased in authorized points of sales of the Guarantor or from authorized distributors. Full list of authorized companies is available on the website www.defro.pl.
- 3) When the whole price will be paid and the product will be issued to the user also the warranty card will be issued. In the warranty card is missing the Purchaser should immediately contact the Seller to obtain this document, while its lack has no influence on the validity and period of the warranty given based on this statement, but it can have an influence on the correct, timely processing of obligations resulting from this warranty by the Guarantor.
- 4) To allow Guarantor efficient operation the Purchaser should immediately after issuance of the product, send back a copy of a correctly completed Warranty Card to the address of the Guarantor (Ruda Strawczyńska 103a, 26-067 Strawczyn). The correctly filled Warranty Card has date, stamp and signatures in designated locations.
- 5) The Purchaser receives Warranty Terms and Conditions, Warranty Card as well as Operating Manual containing conditions for boiler's usage, installation guide and parameters regarding the chimney, fuel and boiler water.
- 6) The Guarantor guarantees that the equipment works correctly provided that all conditions specified in the Operating Manual have been met, especially with respect to parameters applying to fuel, and connection to the chimney system. The warranty covers products used in compliance with their intended use and information provided in the service manual. A guarantor is not responsible for the effect of normal wear and tear of the product which is connected with operation.
- 7) The warranty authorizations period commences on the date of issuance of the product to the Purchaser and equals:
 - a) 5 years for the correct operation of the equipment,
 - b) 2 years for claddings made of heat-resisting concrete - Ceramiton, while the warranty does not cover discolorations, a complete change of the color or degradation of the top layer of the coating.
 - c) 2 years for doors lifting system for DEFRO HOME NAVI fireplace inserts in the G version (guillotine),
 - d) 1 year for grate, deflector and gaskets of the fireplace,
 - e) elements subject to wear-out are not covered by the Warranty; these include: ceramic hardened glass, screws, nuts, handles, bearings, guides, lines etc.
- 8) The Warranty is valid in the Republic of Poland.
- 9) During the warranty period, the Guarantor ensures free-of-charge repairs of any physical defects of the product within the period of:

- a) 14 days after the fault report, unless the repair requires replacement of construction elements of the product;
 - b) 30 days after the fault report, if the repair requires replacement of construction elements of the product; subject to points 3 and 4 of these warranty conditions.
- 10) If, as a result of considering the warranty claim the defective product has been replaced with a new one or the significant repairs have been made, then a new warranty period is applied counting from the date of delivery of the replaced or repaired product. In case when only part, belonging to the claimed product, is replaced then new warranty period is applied only for this part. In the other cases, the warranty period is prolonged by a period when the operation of the product was impossible due to filed claim.
 - 11) Registration of any physical fault to be repaired during the warranty period (fault registration) should be made by the Purchaser immediately after a fault has been found and no later than after 14 days.
 - 12) Any fault is to be registered with the Guarantor (Ruda Strawczyńska 103a, 26-067 Strawczyn) by sending a complaint sheet contained in this operating manual, filled in and stamped by an authorized point of sale or authorized distributor. The fault registration should contain:
 - a) type, capacity, serial number, manufacturer number (the information is located on the rating plate),
 - b) date and place of purchase,
 - c) brief description of the fault,
 - d) detailed address and phone number of the Purchaser.
 - e) If the following cases are complained about: incorrect combustion in the device, tar deposits, smoking through the door; the fault registration should be supplemented with a copy of a chimney sweep expertise certifying that the flue meets all requirements specified in the operating manual for a given boiler's capacity.
 - 13) The Guarantor shall not be responsible for exceeding of the periods mentioned in point 9 above or the Guarantor or its representatives will be ready to remove the defect within the date agreed with the Purchaser and will not be able to carry it out due to the reasons not attributable to the Guarantor (e.g. lack of proper access to devices, lack of energy or water, force majeure, Purchaser is not present etc.).
 - 14) If the Guarantor, despite being ready to carry out the repair, will not be able to carry out the warranty repair twice because of the reasons attributable to the Purchaser then it is assumed that Purchaser had resigned from the claim included in the guarantee claim. Notification about the same defect in this mode is not possible.
 - 15) The product can be replaced if the Guarantor decides it cannot be repaired.
 - 16) The Guarantor does not accept liability for inappropriate choice of product with respect to the heated area (e.g. device of too low or too high power with respect to requirements). It is recommended to choose a device in cooperation with a design office or the Guarantor. The Guarantor is not liable for loss of data saved in the equipment and for economical losses and lost profits.
 - 17) The guarantor will refuse realization of Purchaser's claims resulting from this document in the case when:
 - a) will state damage or ripping of leaden seals,
 - b) identification of product will be impossible (that is conformity of the presented product with a document describing the equipment, replaced or illegible documents),
 - c) damages resulting from incorrect transport carried out or ordered by Purchaser,
 - d) particular components of the equipment were willfully replaced with non-genuine, used etc., repairs outside the authorized service of the Guarantor etc.
 - e) damages are mechanical, chemical, and thermal and they are not resulting from causes in the sold product.
 - f) damages concerns wearing parts, especially: screws, nuts, handles, ceramic and sealing elements,
 - g) damages resulting from product usage inconsistently with the operating manual, that is especially when incorrect equipment operation resulting from lack of chimney draught or inappropriate power of the equipment,
 - h) Faults are not significant and do not have an impact on the use value of the product.
- 18) This warranty does not cover:
 - a) products used for business purposes or industrial uses;
 - b) components of electrical equipment;
 - c) damages caused by the other connected equipment, devices or accessories other than those recommended by the Guarantor.
 - d) damages occurred as a result action of external impacts, among other: by the action of force majeure;
 - e) damages caused by the animals,
 - f) damages resulting from overheating of the equipment that is: discoloration of glass pane, "milky discolorations", discoloration of metal components, "rainbow steel", blue discolorations, chipping of paint, gasket discolorations, deformation of steel components.
 - 19) Warranty repairs accepted by the Guarantor are carried out free of charge. The guarantor can charge the costs connected with the warranty claim only in the case when a claim is not accepted as a result of stating circumstances which are listed in points 17 and 18 mentioned above.
 - 20) Notification of complaint can be considered positively only in the case of:
 - a) keeping the time-limits mentioned in this document;
 - b) fulfilling the other terms and the conditions of the warranty;
 - c) presentation of product proof of purchase - that is invoice or fiscal receipt, the other proof of purchase, in compliance with the regulations;
 - 21) Device installation can be carried out by a person holding general installation qualifications but an entry and stamp in the Warranty Card are required.
 - 22) Device's first start-up, any repairs and other activities, which are not supposed to be carried out by the User according to the operating manual, can be carried out only by an authorized service trained by the Guarantor. The device's first start-up is payable by the Purchaser.
 - 23) During the execution of the warranty repair, the customer is responsible for securing the location of repair, including the system of fireplace insert, adjacent floor, walls etc. If the repair requires removing the housing, then the user is responsible for such removal. Signing the complaint form, indicates that the customer does not have any remarks related to the condition of the equipment's surroundings, including the condition of the system, floor, walls etc. after completion of the repair.
 - 24) Warranty repair is made in the location when the product is operated. If the claim applies to part of the product, including electronic equipment /electronic controller, fan etc. then the given part should be sent to the Guarantor at his expense. Returning faulty equipment is a condition to accept the claim and replace this equipment for free. Not returning the above-mentioned part within seven (7) working days will be subject to not accepting the claim and charging its costs to the purchaser.
 - 25) Provisions of this document do not limit in any way authorizations resulting from the claim submitted on the basis of statutory warranty. The warranty also had no influence on the other claims of the Purchaser, according to the provisions of law - including these concerning non-conformity of the goods with the contract. The purchaser can exercise powers from the statutory warranty regardless of powers resulting from the guarantee. If the purchaser exercises his powers resulting from the warranty, the period for execution of powers resulting from the warranty will be suspended from the date of notice about the defect. This period will be continued from the date of refusal by the Guarantor about the execution of obligations resulting from the warranty or ineffective lapse of time for their execution.

- 26) To all matters not settled in this Warranty Card and document the provisions of the Civil Code Art. 577 - 581 shall apply.

12.1. WARRANTY CONDITIONS "48H SERVICE"

- 1) The "48h Service" program covers the heating equipment manufactured by DEFRO R. Dziubela sp. k.
- 2) Any complaints are to be made at a retail outlet, directly at the Company's e-mail: serwis@defro.pl, or by a letter to the company's address.
- 3) Fault registration can be completed if the Purchaser has a purchase confirmation and has filled in the Warranty Card correctly including a complaint sheet.
- 4) The "48h service" ensures that DEFRO R. Dziubela sp. k. does its best to remove any faults which make it impossible/difficult for the equipment to operate within the period of two business days from the day of fault registration.
- 5) Fault removal time may be prolonged for reasons not dependent on DEFRO R. Dziubela sp. k., such as the necessity of replacement of construction elements, lack of spare parts at the supplier, adverse weather conditions /force majeure/.
- 6) Failure to carry out repairs within this period cannot constitute a ground for any claims against DEFRO R. Dziubela sp. k. and Authorized Service Partner.
- 7) To facilitate contact with service, service hotline for Customers has been set up: 509 702 720 and 509 577 900. If you call on these numbers, you will receive the necessary information and help with any service issue.

We kindly inform you that the possible replacement of the equipment component, with the working one, claimed by the user is not unambiguous with the admission of the equipment user's warranty claims and does not end the complaint processing procedure. DEFRO reserves the right to charge the equipment's user with component replacement/repair costs, which after expertise/repair was stated as damaged by the factors independent of the boiler's manufacturer (e.g. short-circuit in the electric system, overvoltage, flooding, mechanical damages not visible to the naked eye etc.) and which damages were not able to stated during repairing in the location of equipment operation by the service, within 60 days from date of carrying out the repair. DEFRO will issue an appropriate invoice for the replacement/repair of the subject component with the enclosed expertise protocol. At the same time we inform, you that lack of payment for the invoice including the above-mentioned costs within 14 days from its issuance results in irrevocable loss of warranty for the used equipment and this information will be entered into our computer supervision system for equipment within the warranty period. The date when the due amount is credited to the bank account given in the mentioned invoice is treated as the payment date.

WARRANTY CARD

Confirmation of equipment's quality and completeness

In accordance with the conditions stated herein, warranty for a fireplace insert DEFRO HOME NAVI

type operated in accordance with the operating manual has been issued.

Equipment manufacturing number*

Equipment power* kW

User /name and surname/**

Address /street, city, postal code/**

.....

tel./fax** e-mail**

Sale date

Installation date

Start-up date

.....

.....

.....

(stamp and signature of salesperson)

(stamp and signature of salesperson)

(stamp and signature of company starting up
the fireplace insert)

The user confirms that:

- the equipment has been delivered as complete;
- the device showed no failure during the first start-up carried out by a service company,
- has received the Operating Manual and equipment's installation manual with this Warranty Card filled in;
- has been familiarised with equipment's operation and maintenance.

.....
city and data

.....
user signature

* filled by the manufacturer

** filled by the user

The Customer and the installation and service company confirm by their own signature that their personal data can be processed for service register purposes according to the art. 6 section 1, letter a of the General Data Protection Regulation of 27 April 2016 (OJ EU L 119, 04.05.2016).

DEFRO R. Dziubeła spółka komandytowa

• 26-067 Strawczyn, Ruda Strawczyńska 103A • tel. 041 303 80 85 • biuro@defro.pl • www.defro.pl •

14. CARRIED OUT WARRANTY REPAIRS AND MAINTENANCE.

No.	date	fault description, repaired element, description of repairs	comments	Stamp and signature of Service
1.				
2.				
3.				
4.				
5.				
6.				
7.				
8.				
9.				
10.				



WARRANTY CARD

Confirmation of equipment's quality and completeness

In accordance with the conditions stated herein, warranty for a fireplace insert DEFRO HOME NAVI typeoperated in accordance with the operating manual has been issued.

Equipment manufacturing number*

Equipment power* kW

User /name and surname/**

Address /street, city, postal code/**

tel./fax** e-mail**

Sale date

Installation date

Start-up date

.....

(stamp and signature of salesperson)

(stamp and signature of salesperson)

(stamp and signature of company starting up the fireplace insert)

The user confirms that:

- the equipment has been delivered as complete;
- the device showed no failure during the first start-up carried out by a service company,
- has received the Operating Manual and equipment's installation manual with this Warranty Card filled in;
- has been familiarised with equipment's operation and maintenance.

.....
city and data

.....
user signature

* filled by the manufacturer

** filled by the user

The Customer and the installation and service company confirm by their own signature that their personal data can be processed for service register purposes according to the art. 6 section 1, letter a of the General Data Protection Regulation of 27 April 2016 (OJ EU L 119, 04.05.2016).



COMPLAINT FORM

made on in connection with complaint no.

SUBJECT OF COMPLAINT

EQUIPMENT TYPE: Equipment manufacturing date:
Equipment serial no.: Equipment purchase date:

CLAIMANT

Name and surname:
Detailed address:

Phone number:

DETAILED DESCRIPTION OF QUALITY FAULTS OR FAULTS RESULTING FROM THE MANUFACTURER'S FAULT

.....
.....
.....

OTHER FAULTS

CONDITION OF THE EQUIPMENT SURROUNDINGS (also photo documentation before and after the repair, made by the service technician)

CLAIMANT LODGES WARRANTY CLAIM FOR (SELECT APPROPRIATE):

Warranty repair Paid repair Post-warranty paid repair

CLAIMANT REQUESTS.....

In the case when a claim is not taken into consideration because circumstances, mentioned in p. 17 and 18 of the Warranty Terms are discovered, the CLAIMANT agrees to cover the costs incurred by the manufacturer's service.

.....
(city and data) (sign of claimant) (signature of serviceman)

FAULT REMOVAL - to be filled by service

Date of informing the service technician about faulthour

Name and surname of service technician

Way of fault removal

Advice (DESCRIPTION)

END OF COMPLAINT

Name and surname of service technician: Fault removal date:

Justness of complaint: Duration of repair:

Fault (defect) has been removed, the equipment operates correctly. I hereby confirm the removal of the fault. I declare that I have familiarised myself with the conditions of the warranty on the basis of which I wish to register my complaint.

The Customer and the installation and service company confirm by their own signature that their personal data can be processed for service register purposes according to the art. 6 section 1, letter a of the General Data Protection Regulation of 27 April 2016 (EU L 119, 04.05.2016).

.....
(city and data) (sign of claimant) (signature of serviceman)

ATTENTION! In the case when a claim is not taken into consideration because circumstances, mentioned in p. 17 and 18 of the Warranty Terms are discovered, the CLAIMANT agrees to cover the costs incurred by the manufacturer's service.*
*cost per man-hour and traveling expenses are calculated according to the current price list available at www.defro.pl.



COMPLAINT FORM

made on in connection with complaint no.

SUBJECT OF COMPLAINT

EQUIPMENT TYPE: Equipment manufacturing date:
Equipment serial no.: Equipment purchase date:

CLAIMANT

Name and surname:
Detailed address:

Phone number:

DETAILED DESCRIPTION OF QUALITY FAULTS OR FAULTS RESULTING FROM THE MANUFACTURER'S FAULT

.....
.....
.....

OTHER FAULTS

CONDITION OF THE EQUIPMENT SURROUNDINGS (also photo documentation before and after the repair, made by the service technician)

CLAIMANT LODGES WARRANTY CLAIM FOR (SELECT APPROPRIATE):

Warranty repair Paid repair Post-warranty paid repair

CLAIMANT REQUESTS

In the case when a claim is not taken into consideration because circumstances, mentioned in p. 17 and 18 of the Warranty Terms are discovered, the CLAIMANT agrees to cover the costs incurred by the manufacturer's service.

.....
(city and data) (sign of claimant) (signature of serviceman)

FAULT REMOVAL - to be filled by service

Date of informing the service technician about faulthour

Name and surname of service technician

Way of fault removal

Advice (DESCRIPTION)

END OF COMPLAINT

Name and surname of service technician: Fault removal date:

Justness of complaint: Duration of repair:

Fault (defect) has been removed, the equipment operates correctly. I hereby confirm the removal of the fault. I declare that I have familiarised myself with the conditions of the warranty on the basis of which I wish to register my complaint.

The Customer and the installation and service company confirm by their own signature that their personal data can be processed for service register purposes according to the art. 6 section 1, letter a of the General Data Protection Regulation of 27 April 2016 (EU L 119, 04.05.2016).

.....
(city and data) (sign of claimant) (signature of serviceman)

ATTENTION! In the case when a claim is not taken into consideration because circumstances, mentioned in p. 17 and 18 of the Warranty Terms are discovered, the CLAIMANT agrees to cover the costs incurred by the manufacturer's service.*

*cost per man-hour and traveling expenses are calculated according to the current price list available at www.defro.pl.



COMPLAINT FORM

made on in connection with complaint no.

SUBJECT OF COMPLAINT

EQUIPMENT TYPE: Equipment manufacturing date:
Equipment serial no.: Equipment purchase date:

CLAIMANT

Name and surname:
Detailed address:

Phone number:

DETAILED DESCRIPTION OF QUALITY FAULTS OR FAULTS RESULTING FROM THE MANUFACTURER'S FAULT

.....
.....
.....
.....

OTHER FAULTS

CONDITION OF THE EQUIPMENT SURROUNDINGS (also photo documentation before and after the repair, made by the service technician)

CLAIMANT LODGES WARRANTY CLAIM FOR (SELECT APPROPRIATE):

Warranty repair Paid repair Post-warranty paid repair

CLAIMANT REQUESTS

In the case when a claim is not taken into consideration because circumstances, mentioned in p. 17 and 18 of the Warranty Terms are discovered, the CLAIMANT agrees to cover the costs incurred by the manufacturer's service.

.....
(city and data) (sign of claimant) (signature of serviceman)

FAULT REMOVAL - to be filled by service

Date of informing the service technician about faulthour

Name and surname of service technician

Way of fault removal

Advice (DESCRIPTION)

END OF COMPLAINT

Name and surname of service technician: Fault removal date:



Justness of complaint: Duration of repair:

Fault (defect) has been removed, the equipment operates correctly. I hereby confirm the removal of the fault. I declare that I have familiarised myself with the conditions of the warranty on the basis of which I wish to register my complaint.

The Customer and the installation and service company confirm by their own signature that their personal data can be processed for service register purposes according to the art. 6 section 1, letter a of the General Data Protection Regulation of 27 April 2016 (EU L 119, 04.05.2016).

.....
(city and data) (sign of claimant) (signature of serviceman)

ATTENTION! In the case when a claim is not taken into consideration because circumstances, mentioned in p. 17 and 18 of the Warranty Terms are discovered, the CLAIMANT agrees to cover the costs incurred by the manufacturer's service.*
*cost per man-hour and travelling expenses are calculated according to the current price list available at www.defro.pl.

		PRODUCT SHEET IN ACCORDANCE WITH THE EU REGULATION 2015/1186 SUPPLEMENTING THE DIRECTIVE OF THE EUROPEAN PARLIAMENT AND THE COUNCIL 2010/30 EU	
Name and address of the equipment supplier		DEFRO R. Dziubela spółka komandytowa 26-067 Strawczyn Ruda Strawczyńska 103A	
PARAMETERS OF THE EQUIPMENT	UNIT	MODEL IDENTIFICATION	
		DEFRO HOME NAVI SM DEFRO HOME NAVI SM G	DEFRO HOME NAVI ME DEFRO HOME NAVI ME G
Energy efficiency class	-		
Direct thermal output	kW	3.7	6.8
Indirect thermal output	kW	10.3	10.2
Energy Efficiency Index EEI	-	111	112
Efficiency at rated thermal output	%	83.4	83.9
Efficiency at minimal thermal output	%	N/A	N/A
Special precautions during assembly, installation or maintenance of the equipment	-	Consider guidelines included in the Service Manual delivered by the manufacturer each time before assembly, start-up or maintenance of the equipment.	

PRODUCT SHEET

in accordance with the Commission Regulation 2015/1185

on the execution of the Directive of the European Parliament and the Council 2009/125/EC

Equipment parameters

Model identifier(s): **DEFRO HOME NAVI SM, DEFRO HOME NAVI SM G**

Indirect heating function: [yes/~~no~~]

Direct thermal output: 3.7 (kW)

Indirect thermal output: 10.3 (kW)

Fuel	Recom- mended fuel (only one):	Other suitable fuel(s):	η_s [%]:	Emission from local space heater at rated heat output				Emission from local space heaters at rated heat output			
				PM	OGC	CO	NO _x	PM	OGC	CO	NO _x
				mg/Nm ³ (13 % O ₂)				mg/Nm ³ (13 % O ₂)			
Chunks of wood of moisture content ≤ 25 %	yes	no	73	40	120	1500	200				
Pressed wood of moisture content ≤ 12 %	no	no									
Other wooden biomass	no	no									
Non-wooden biomass	no	no									
Hard coal and lean coal	no	no									
Metallurgic coke	no	no									
Semi-coke	no	no									
Hard coal	no	no									
Brown coal briquettes	no	no									
Peat briquettes	no	no									
Briquettes made of mixed fossil fuel	no	no									
Other fossil fuel	no	no									
Briquettes made of mix of biomass and fossil fuel	no	no									
Other mixture of biomass and solid fuel	no	no									

Properties in the case of operation only with recommended fuel

Parameter	Designation	Value	Unit	Parameter	Designation	Value	Unit
Thermal output				Performance (calorific value in operating condition)			
Rated heat output	P_{nom}	14	kW	Performance at rated thermal power	$\eta_{th,nom}$	83.4	%
Minimum heat output (indicative)	P_{min}	-	kW	Performance at minimal thermal power (indicative)	$\eta_{th,min}$	N/A	%
Auxiliary power consumption				Type of heat output/control of temperature in the room (choose one option)			
For rated heat output	e_{lmax}	--	kW	single-stage thermal power without temperature control in the room		yes/no	
For minimum heat output	e_{lmin}	-	kW	at least two manual stages without temperature control in the room		yes/no	
In standby mode	e_{lsb}	-	kW	mechanical control of temperature in the room using a thermostat		yes/no	
Energy demand of the fixed ignition flame				electronic control of temperature in the room		yes/no	
Energy demand of the ignition flame (if applicable)	P_{pilot}	-	kW	electronic control of temperature in the room and daily controller		yes/no	
				electronic control of temperature in the room and weekly controller		yes/no	
				Other control options (you may choose several options)			
				temperature control in the room with presence detection		yes/no	
				temperature control in the room with open window detection		yes/no	
				remote control option		yes/no	

Name/name and surname and address of the manufacturer or his/her authorized representative:

DEFRO R. Dziubeła spółka komandytowa
26-067 Strawczyn
Ruda Strawczyńska 103A

Robert Dziubeła – CEO

PRODUCT SHEET

in accordance with the Commission Regulation 2015/1185

on the execution of the Directive of the European Parliament and the Council 2009/125/EC

Equipment parameters

Model identifier(s): **DEFRO HOME NAVI ME, DEFRO HOME NAVI ME G**

Indirect heating function: [yes/∅]

Direct thermal output: 6.8 (kW)

Indirect thermal output: 10.2 (kW)

Fuel	Recom- mended fuel (only one):	Other suitable fuel(s):	η_s [%]:	Emission from local space heater at rated heat output				Emission from local space heaters at rated heat output			
				PM	OGC	CO	NO _x	PM	OGC	CO	NO _x
				mg/Nm ³ (13 % O ₂)				mg/Nm ³ (13 % O ₂)			
Chunks of wood of moisture content ≤ 25 %	yes	no	74	40	120	1500	200				
Pressed wood of moisture content ≤ 12 %	no	no									
Other wooden biomass	no	no									
Non-wooden biomass	no	no									
Hard coal and lean coal	no	no									
Metallurgic coke	no	no									
Semi-coke	no	no									
Hard coal	no	no									
Brown coal briquettes	no	no									
Peat briquettes	no	no									
Briquettes made of mixed fossil fuel	no	no									
Other fossil fuel	no	no									
Briquettes made of mix of biomass and fossil fuel	no	no									
Other mixture of biomass and solid fuel	no	no									

Properties in the case of operation only with recommended fuel

Parameter	Designation	Value	Unit	Parameter	Designation	Value	Unit
Thermal output				Performance (calorific value in operating condition)			
Rated heat output	P_{nom}	17	kW	Performance at rated thermal power	$\eta_{th,nom}$	83.9	%
Minimum heat output (indicative)	P_{min}	-	kW	Performance at minimal thermal power (indicative)	$\eta_{th,min}$	N/A	%
Auxiliary power consumption				Type of heat output/control of temperature in the room (choose one option)			
For rated heat output	$e_{l_{max}}$	-	kW	single-stage thermal power without temperature control in the room		yes/no	
For minimum heat output	$e_{l_{min}}$	-	kW	at least two manual stages without temperature control in the room		yes/no	
In standby mode	$e_{l_{sb}}$	-	kW	mechanical control of temperature in the room using a thermostat		yes/no	
Energy demand of the fixed ignition flame				electronic control of temperature in the room		yes/no	
Energy demand of the ignition flame (if applicable)	P_{pilot}	-	kW	electronic control of temperature in the room and daily controller		yes/no	
				electronic control of temperature in the room and weekly controller		yes/no	
				Other control options (you may choose several options)			
				temperature control in the room with presence detection		yes/no	
				temperature control in the room with open window detection		yes/no	
				remote control option		yes/no	

Name/name and surname and address of the manufacturer or his/her authorized representative:

DEFRO R. Dziubeła spółka komandytowa
26-067 Strawczyn
Ruda Strawczyńska 103A

Robert Dziubeła – CEO

DEFRO
home

DEFRO R. Dziubeła spółka komandytowa

26-067 Strawczyn
Ruda Strawczyńska 103A
tel.: 41 303 80 85
biuro@defro.pl
www.defrohome.pl

Infolinia serwisowa
509 702 720
509 577 900